

Mach4 CNC Controller Mill Programming Guide

10/26/22

Copyright © 2014 Newfangled Solutions, Artsoft USA, All Rights Reserved

The following are registered trademarks of Microsoft Corporation: Microsoft, Windows. Any other trademarks used in this manual are the property of the respective trademark holder.

Table of Contents

Chapter 1: Introduction.....	6
Glossary.....	7

Format.....	9
Rotary vs. Linear	10
Chapter 2: G Code List.....	11
G Code Descriptions and Examples.....	14
G00 – Rapid Move.....	14
G01 – Linear Feed Move.....	14
G02/G03 – Arc Feed Move.....	15
G04 – Dwell.....	17
G09 – Exact Stop.....	18
G10 L1 – Tool Offset Setting.....	18
G10 L2 – Fixture Offset Setting.....	20
G10 L3 – Tool Life Management Setting.....	22
G10 L3 Format 1 - Register with deleting all groups.....	23
G10 L3 Format 2 – Add or change tool group.....	24
G10 L3 Format 3 – Delete tool life data.....	25
G10 L10 – Geometry compensation value for H code.....	25
G10 L11 – Wear compensation value for H code.....	26
G10 L12 – Geometry compensation value for D code.....	26
G10 L13 – Wear compensation value for D code.....	27
G10 L20 – Additional Fixture Offset Setting.....	27
G12/G13 – Circle Interpolation.....	30
G15/G16 – Polar Coordinates.....	31
G17/G18/G19 – Plane Selection.....	32
G20/G21 – Unit selection.....	33
G28 – Zero Return.....	34
G28.1 – Home Axis.....	35
G30 – 2nd, 3rd, 4th Zero Return.....	35
G31/G31.X – Probe function.....	36
G32 – Threading.....	37
G40 – Cutter Compensation Cancel.....	38
G40.1 – Arc Type Cutter Compensation.....	38
G40.2 – Line Offset Type Cutter Compensation.....	40

G41/G42 – Cutter Compensation Left/Right.....	40
G43/G44 – Tool Length Offset.....	40
G49 – Tool Length Offset Cancel.....	40
G50 – Scaling Cancel.....	40
G51 – Scaling/Mirroring Function.....	41
G52 – Local Coordinate System Shift.....	42
G53 – Machine Coordinate System.....	43
G54-G59 – Fixture Offset.....	43
G54.1 – Additional Fixture Offsets.....	43
G60 – Unidirectional Approach.....	44
G61 – Exact Stop Mode.....	45
G64 – Constant Velocity Mode.....	45
G65 – Macro Call.....	45
G66 – Macro Modal Call.....	46
G67 – Macro Modal Call Cancel.....	46
G68 – Coordinate System Rotation.....	46
G69 – Coordinate System Rotation Cancel.....	47
G73-G89 – Canned Cycles.....	48
G90/G91 – Absolute/Incremental Position Mode.....	48
G90.1/G91.1 – Absolute/Incremental Arc Center Mode.....	50
G92 – Local Coordinate System Setting.....	51
G93 – Inverse Time Feed.....	52
G94 – Feed Per Minute.....	52
G95 – Feed Per Revolution.....	52
G96 – Constant Surface Speed.....	52
G97 – Constant RPM.....	52
G98 – Initial Point Return.....	53
G99 – R Point Return.....	53
Chapter 3: Canned Cycles.....	54
 G80 – Canned Cycle Cancel.....	56
Drilling.....	57
 G81 – Drilling.....	57

G82 – Spot Face.....	58
G83 – Peck Drilling.....	59
G73 – High Speed Peck.....	61
Tapping.....	63
G84 – Right Hand Tapping.....	63
G74 – Left Hand Tapping.....	64
G84.2/G84.3 – Right and Left Hand Rigid Tapping.....	65
Boring.....	66
G76 – Fine Boring.....	66
G85 – Boring, Feed rate Retract.....	68
G86 – Boring, Rapid Retract.....	68
G87 – Back Boring.....	69
G88 – Boring, Manual Retract.....	71
G89 – Boring, Dwell & Feed rate Retract.....	71
Chapter 4: Cutter Compensation.....	73
Chapter 5: M Code List.....	75
M Code Descriptions.....	75
M00 – Mandatory Program Stop.....	75
M01 – Optional Program Stop.....	75
M02 – Program End.....	75
M03 – Spindle Forward/Clockwise.....	76
M04 – Spindle Reverse/Counterclockwise.....	76
M05 – Spindle Stop.....	76
M06 – Tool Change.....	76
M07 – Mist Coolant On.....	76
M08 – Flood Coolant On.....	77
M09 – All Coolant Off.....	77
M19 – Spindle Orient.....	77
M30 – Program End and Rewind.....	77
M48 – Enable Feed rate/Spindle Speed Overrides.....	77
M49 – Disable Feed rate/Spindle Speed Overrides.....	77
M62 – Synchronized Output On.....	77

M63 – Synchronized Output Off.....	77
M64 – Immediate Output On.....	77
M65 – Immediate Output Off.....	78
M66 – Wait for Input.....	78
M67 – Synchronized Analog Output.....	78
M68 – Analog Output Immediate.....	78
M98 – Subprogram Call.....	79
M99 – Return From Subprogram / Rerun.....	81
Custom M Codes.....	81
Chapter 6: Custom Macro.....	82
 Variables.....	82
 System Variables.....	85
 Arithmetic and Logic.....	91

Chapter 1: Introduction

G Code is a special programming language that is interpreted by Computer Numerical Control (CNC) machines to create motion and other tasks. It is a language that can be quite complex at times and can vary from machine to machine. The basics, however, are much simpler than it first appears and for the most part follows an industry adopted standard. Mach4 has made a large leap closer to this standard.

An important point to remember when reading this manual: In describing motion of a machine it will always be described as tool movement relative to the work piece. In many machines the work piece will move in more axes than the tool; however the program will always define tool movement around the work piece. Axis directions follow the right hand rule, see figure A.

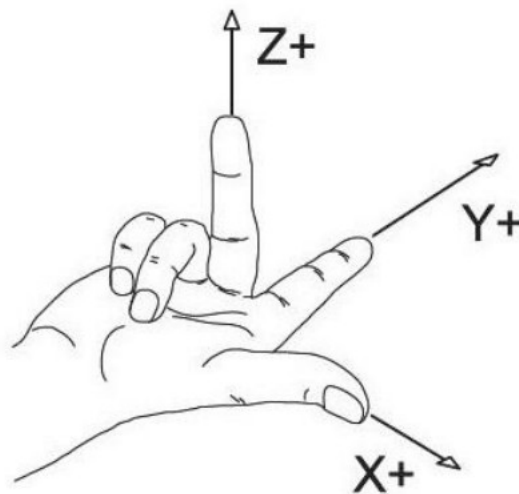

Figure A: Right hand rule

Glossary

Block	A single line of G Code
Canned Cycle	Complex cycle defined by a single block of code, used to simplify programming
Dwell	Program pause with a duration defined by "P" in seconds. If "P" contains a decimal point, the time is in seconds.
EOB	End of block. Required at the end of every block of G Code. In Mach4 this is a carriage return
Feed rate	Velocity, set by F, at which an axis will move
Group	Collection of G codes that control the same function or mode, i.e. G90 and G91 positioning modes
Modal	Active until a code from the same group is called
Normal	A line perpendicular to a plane, pointing in the positive direction.
Origin	Point in a coordinate system where X, Y and Z are zero
RPM	Revolutions per minute
UPM	Units per minute (inches, millimeters, degrees, etc)
Word	A single word of G Code is a letter followed by a number. G01, X1.0, etc. are words
G	Preparatory function, G followed by a numerical code, specifies machining modes and functions
M	Miscellaneous function, M followed by a numerical code, defines program flow and can control auxiliary functions such as coolant. Can also perform machine specific functions and macros user or builder.
X, Y, Z, A, B, C, U, V, W	Movement commands followed by a numerical value, define the end point of a motion command. (A, B, C are rotary, U, V, W are linear replacements for A, B, C)
S	Spindle speed, followed by numerical value of desired rpm or surface speed
T	Tool call, followed by next tool number to be used
H	Tool height offset to be used, generally matches the tool number
D	Tool diameter offset to be used, generally matches the tool number
F	Followed by a numerical value to define the feed rate. The magnitude and value of which will be determined by the feed mode setting

- P Followed by a numerical value, specifies dwell time in milliseconds. (also used in other functions) If the value contains a decimal point, the dwell time is in seconds.
- N Sequence numbers. Used for program organization and go to commands

Format

In writing G Code programs there are some rules to be aware of as well as some general formatting guidelines that should be followed or at least considered.

The first part of any program should be a safe start up block. This line of code is used to make sure that some modes are disabled and others are set to their most common setting. An example safe start block would look like this:

```
G00 G90 G17 G54 G40 G49 G80
```

This block of code tells the machine that we want to be in rapid mode and using absolute position in the XY plane of fixture offset 1. At the same time we want to cancel any tool diameter and length offsets and make sure any active canned cycles are cancelled.

G00 – Rapid mode

G90 – Absolute position mode

G17 – XY plane select

G54 – Fixture offset 1

G40 – Cutter compensation (tool diameter) cancel

G49 – Length offset cancel

G80 – Canned cycle cancel

It is recommended that this safe start block be used at the start of the program and also before or immediately following every tool change. It is common to restart a program from a tool change, having the safe start line there can greatly reduce the chance of a machine not acting as expected, the results of which can be aggravating at best and a crash at worst. The safe start block shown here is just an example. Every machine and every programmer are a little different and each will have their own start up block.

Jumping to the end of the program there is not a lot required. Typically there will be a couple blocks of code to return the Z axis to the home position and maybe move the work piece closer to the operator for easier loading and unloading of parts. Shutting off the spindle and coolant or any other accessories is also a good idea here. The final block in a program is a program end code, most commonly M30 but there are other options. Make sure this final block is followed by an end of block. It is easy to forget this last EOB in a program for Mach because it is just a carriage return and not always readily apparent. One way to make sure that there is always an EOB on your program end block is to follow it with %. Like this:

```
.  
.   
.   
M30  
%
```

This percent sign is a familiar symbol to CNC programmers in industry; however any symbol or character can be used as it will not be read by the control because of the program end before it. If there is no EOB following the percent sign it will not show up in the program when loaded into Mach.

In between the start and end is the body of the program. There are a few rules here. Each block of code will contain a combination of words. Multiple G codes can be specified in a single block, however if more than one from the same modal group is specified the last one in the block will be valid, with the exception of group 00. Modal G codes stay active until another from the same group is called. For example; G01 is modal so it is not necessary to put it in consecutive blocks. Once active every successive positioning block will be in the G1 mode unless another code from group one is called (G00, G02, G03, etc.). All G codes not in group 0 behave this way.

Only one M code can be specified in a single block. Same holds true for all other words.

Generally leading zeroes are not required in G Code. For example G01 and G1 are the same. The same holds true for M codes, position commands, feed rates, etc. When specifying values for position, feed rate, variables, etc., it is good practice to always use a decimal point and trailing zero, instead of X1 use X1.0. Although the decimal point is not required (in Mach X1 = X1.0) it is HIGHLY recommended.

Rotary vs. Linear

Axis designations A, B, and C are typically rotary axes that are parallel to axes X, Y, and Z, respectively. Linear control of these axes are available with axis designation U, V, and W. Any movement command that accepts A, B, or C axes will also accept U, V, or W.

Chapter 2: G Code List

Code	Group	Description	Modal	Page
G00	1	Rapid Move	Y	14
G01	1	Linear Feed Move	Y	14
G02	1	Clockwise Arc Feed Move	Y	15
G03	1	Counter Clockwise Arc Feed Move	Y	15
G04	0	Dwell	N	17
G09	0	Exact stop	N	18
G10 L1	0	Tool Offset Setting	Y/N	19
G10 L2	0	Fixture Offset Setting	Y/N	21
G10 L3	0	Tool Life Management Setting	Y	23
...	0	G10 L3 Format 1 - Delete and Add	Y	24
...	0	G10 L3 Format 2 – Add or Change	Y	25
...	0	G10 L3 Format 3 – Delete Group	Y	26
G10 L10	0	Geometry compensation value for H code	Y/N	26
G10 L11	0	Wear compensation value for H code	Y/N	27
G10 L12	0	Geometry compensation value for D code	Y/N	27
G10 L13	0	Wear compensation value for D code	Y/N	28
G10 L20	0	Additional Fixture Offset Setting	Y/N	28
G10 L50	0	Parameter Setting	Y	30
G11	0	Cancel Modal G10	N	30
G12	1	Clockwise Circle	Y	31
G13	1	Counter Clockwise Circle	Y	31
G15	17	Polar Coordinate Cancel	Y	32
G16	17	Polar Coordinate	Y	32
G17	2	XY Plane Select	Y	34
G18	2	ZX Plane Select	Y	34
G19	2	YZ Plane Select	Y	34
G20	6	Inch	Y	35
G21	6	Millimeter	Y	35
G28	0	Zero Return	N	36
G28.1	0	Home Axis	N	37
G30	0	2 nd , 3 rd , 4 th Zero Return	N	37
G31	1	Probe function	N	38
G32	1	Threading*	N	39
G40	7	Cutter Compensation Cancel	Y	40
G40.1	18	Arc Type Cutter Compensation	Y	40
G40.2	18	Line Offset Type Cutter Compensation	Y	42
G41	7	Cutter Compensation Left	Y	42
G42	7	Cutter Compensation Right	Y	42
G43	8	Tool Length Offset + Enable	Y	42

G44	8	Tool Length Offset - Enable	Y	42
G49	8	Tool Length Offset Cancel	Y	42
G50	11	Cancel Scaling	Y	42
G51	11	Scale Axes	Y	43
G52	0	Local Coordinate System Shift	Y	44
G53	0	Machine Coordinate System	N	45
G54	14	Fixture Offset 1	Y	45
G54.1	14	Additional Fixture Offsets	Y	45
G55	14	Fixture Offset 2	Y	45
G56	14	Fixture Offset 3	Y	45
G57	14	Fixture Offset 4	Y	45
G58	14	Fixture Offset 5	Y	45
G59	14	Fixture Offset 6	Y	45
G60	0	Unidirectional Approach	N	46
G61	15	Exact Stop Mode	Y	47
G64	15	Cutting Mode (Constant Velocity)	Y	47
G65	0	Macro Call	N	47
G66	12	Macro Modal Call	Y	48
G67	12	Macro Modal Call Cancel	Y	48
G68	16	Coordinate System Rotation	Y	48
G69	16	Coordinate System Rotation Cancel	Y	49
G73	9	High Speed Peck Drilling	Y	63
G74	9	LH Tapping*	Y	66
G76	9	Fine Boring*	Y	68
G80	9	Canned Cycle Cancel	Y	58
G81	9	Hole Drilling	Y	59
G82	9	Spot Face	Y	60
G83	9	Deep Hole Peck Drilling	Y	61
G84	9	RH Tapping	Y	65
G84.2	9	RH Rigid Tapping*	Y	67
G84.3	9	LH Rigid Tapping*	Y	67
G85	9	Boring, Retract at Feed, Spindle On	Y	70
G86	9	Boring, Retract at Rapid, Spindle Off	Y	71
G87	9	Back Boring*	Y	72
G88	9	Boring, Manual Retract	Y	74
G89	9	Boring, Dwell, Retract at Feed, Spindle On	Y	75
G90	3	Absolute Position Mode	Y	50
G90.1	4	Arc Center Absolute Mode	Y	52
G91	3	Incremental Position Mode	Y	50
G91.1	4	Arc Center Incremental Mode	Y	52
G92	0	Local Coordinate System Setting	Y	53
G92.1	0	Local Coordinate System Cancel	Y	53
G93	5	Inverse Time Feed	Y	54
G94	5	Feed per Minute	Y	54

G95	5	Feed per Revolution*	Y	54
G96	13	Constant Surface Speed*	Y	54
G97	13	Constant Speed	Y	54
G98	10	Initial Point Return	Y	55
G99	10	R Point Return	Y	55

* Implementation based on machine and control configuration

G Code Descriptions and Examples

G00 – Rapid Move

Rapid moves are used to move from point to point in free space, not cutting material. These moves do not require a feed rate input as they take place at max velocity of the machine. In absolute position mode (G90) X, Y and Z define the end point of the move in the user coordinate system. In incremental position mode (G91) X, Y and Z define the distance and direction to move from the current position.

Format: G00 X__ Y__ Z__

Example: Program a rapid move to X1.0, Y3.0

G0 G90 G54 G17 G40 G49 G80	Safe start line
T1 M6	Tool change
S2500 M3	Start spindle
G0 X1.0 Y3.0	Rapid to XY position
M30	Program end and rewind

G01 – Linear Feed Move

Linear feed moves are point to point moves in a straight line at a federate specified by F. The moves are interpolated so all axes in motion reach the end point at the same time. In absolute position mode (G90) X, Y and Z define the end point of the move in the user coordinate system. In incremental position mode (G91) X, Y and Z define the distance and direction to move from the current position.

Format: G01 X__ Y__ Z__ F__.

Example: Program a feed move from X1, Y3, to X10, Y-1 at a feed rate of 15 UPM.

G0 G90 G54 G17 G40 G49 G80	Safe start line
T1 M6	Tool change
S2500 M3	Start spindle
G94	Feed per minute mode
G0 X1.0 Y3.0	Rapid to XY position
G1 X10.0 Y-1.0 F15.0	Move to XY position at feed rate
M30	Program end and rewind

G02/G03 – Arc Feed Move

Used to cut an arc at a feedrate specified by F. An arc is defined by its start and end points, its radius or center point, a direction, and a plane. Direction is determined by G02, clockwise, and G03, counterclockwise, when viewed from the plane's positive direction (If XY plane is selected look down so that the X axis positive direction is pointing to the right, and the Y axis positive direction is pointing forward). See figure 2-1 for a graphic representation of the motion of a G02. The start point is the current position of the machine. Specify the end point with X, Y, and Z. The values input for the end point will depend on the current G90/G91 (abs/inc) setting of the machine. Only the two points in the current plane are required for an arc. Adding in the third point will create a helical interpolation.

Next is to specify the radius or the center point of the arc, only one or the other, not both.

- To specify the radius, use R and input the actual radius of the desired arc, see Format 2. When an arc is created knowing only start and end points and a radius there are two possible solutions, an arc with a sweep less than 180° and one with sweep greater than 180°. The sign of the radius value, positive or negative, determines which arc will be cut, see figure 2-2. A positive value for R cuts an arc with sweep less than 180°. A negative value for R cuts an arc with sweep greater than 180°.
- A more accurate and reliable way to define an arc is by specifying the center point, this is done with arguments I, J, and K, see Format 1. The center point must be defined in the current plane. I, J, and K correspond to X, Y, Z respectively; the current plane selection will determine which two are used. XY plane (G17) would use I and J for example. Mach has two settings for how I, J, and K should be specified, absolute and incremental. This setting can be changed by G code, G90.1 and G91.1, or in the general tab in the Mach configuration. This setting is independent of the G90/G91 setting. If arc center mode is set to incremental then I, J, K are the distance and direction from the start point to the center point of the arc. If arc center mode is set to absolute then I, J, K are the absolute position of the arc center point in the current user coordinate system.

Format 1: (G17) G02/03 X__ Y__ I__ J__ F__

(G18) G02/03 X__ Z__ I__ K__ F__

(G19) G02/03 Y__ Z__ J__ K__ F__

Format 2: (G17) G02/03 X__ Y__ R__ F__

(G18) G02/03 X__ Z__ R__ F__

(G19) G02/03 Y__ Z__ R__ F__

Example: Program an arc centered at 1.0, 0.0 in the XY plane with radius 2. Start point at 3.0,0.0 and sweep 90 degrees counter clockwise. Feed rate 10 UPM. (Arc center mode set to incremental)

Format 1:

G0 G90 G54 G17 G40 G49 G80	Safe start line
T1 M6	Tool change
S2500 M3	Start spindle
G0 X3.0 Y0.0	Position to X and Y start point

G43 H1 Z.5	Activate tool offset 1 and move to Z rapid plane
G94	Feed per minute mode
G1 Z0.0 F10.0	Z plunge at feed rate
G3 X1.0 Y2.0 I-2.0 J0.0 F10.0	Arc move
G0 Z.5	Retract Z to rapid plane
G0 G53 Z0.0	Return Z to home
M30	Program end and rewind

Format 2:

G0 G90 G54 G17 G40 G49 G80	Safe start line
T1 M6	Tool change
S2500 M3	Start spindle
G0 X3.0 Y0.0	Position to X and Y start point
G43 H1 Z.5	Activate tool offset 1 and move to Z rapid plane
G94	Feed per minute mode
G1 Z0.0 F10.0	Z plunge at feed rate
G3 X1.0 Y2.0 R2.0 F10.0	Arc move
G0 Z.5	Retract Z to rapid plane
G0 G53 Z0.0	Return Z to home
M30	Program end and rewind

A helical interpolation is defined very similar to an arc. The only difference is the addition of the third coordinate of the end point. This third coordinate will define the height of the helix. See the following format for what this looks like in the XY plane:

Format 1: (G17) G02/03 X__ Y__ Z__ I__ J__ F__

Format 2: (G17) G02/03 X__ Y__ Z__ R__ F__

Example: Program a helix with radius 1.0 and center point 0.0, 0.0 in the X,Y plane, start point 0.0, .5, height 1.0 with initial Z at 0.0. Feed rate 10 UPM. Arc sweep should be 270° clockwise. See figure 2-2 for the tool path.

G0 G90 G54 G17 G40 G49 G80	Safe start line
T1 M6	Tool change
S2500 M3	Start spindle
G0 X0.0 Y.5	Position to X and Y start point
G43 H1 Z.5	Activate tool offset 1 and move to Z rapid plane
G94	Feed per minute mode
G1 Z0.0 F10.0	Z plunge at feed rate
G2 X-.5 Y0.0 Z-1.0 I0.0 J-.5 F10.0	Helical interpolation
G0 Z.5	Retract Z to rapid plane
G0 G53 Z0.0	Return Z to home
M30	Program end and rewind

G04 – Dwell

A dwell is simply a pause in the program. The duration of the dwell is specified by P or X in milliseconds with no decimal point. If a decimal point is used, then P or X specifies seconds. The dwell may also be specified with U without a decimal point for milliseconds. No machine movement will take place during a dwell. No auxiliary codes will be turned off, i.e. if the spindle is on it will stay on, coolant will stay on, etc.

The dwell must be the only G code in the block.

Format 1: G04 P__

Format 2: G04 X__

Format 3: G04 U__

Example: Program a 5 second dwell after positioning to X1.0, Z1.0 (using no decimal point to specify milliseconds).

G0 G54 G18 G40 G80	Safe start line
T0101	Tool change
S2500 M3	Start spindle
G0 X1.0 Z1.0	Rapid to XZ position
G4 P5000	Dwell for 5 seconds
M30	Program end and rewind

Example: Program a 5 second dwell after positioning to X1.0, Z1.0 (using decimal point to specify seconds).

G0 G54 G18 G40 G80	Safe start line
T0101	Tool change
S2500 M3	Start spindle
G0 X1.0 Z1.0	Rapid to XZ position
G4 P5.	Dwell for 5 seconds
M30	Program end and rewind

G09 – Exact Stop

G09 is a non-modal exact stop. Machine accelerations cause corners to be slightly rounded; when a true sharp corner is required G09 should be used. Although similar to G61 in function, G09 is not modal while G61 is. When G09 is included in a movement block, axis motion is decelerated to the end point of motion and the position is checked to be exactly as specified. This position check at the end of the move ensures that the machine actually reaches the desired position before moving onto the next block

Format: G01 G09 X__ Y__ F__

Example: Program a 2.0 inch square centered at X0.0, Y0.0 with true sharp corners at X1.0, Y1.0 and X-1.0, Y-1.0, feed rate 15.0 UPM

G0 G90 G54 G17 G40 G49 G80	Safe start line
T1 M6	Tool change
S2500 M3	Start spindle
G94	Feed per minute mode
G0 X-1.0 Y1.0	Rapid to XY position
G1 G9 X1.0 F15.0	Move to position at feed rate, exact stop active
Y-1.0	Move to position at feed rate
G9 X-1.0	Move to position at feed rate, exact stop active
Y1.0	Move to position at feed rate
M30	Program end and rewind

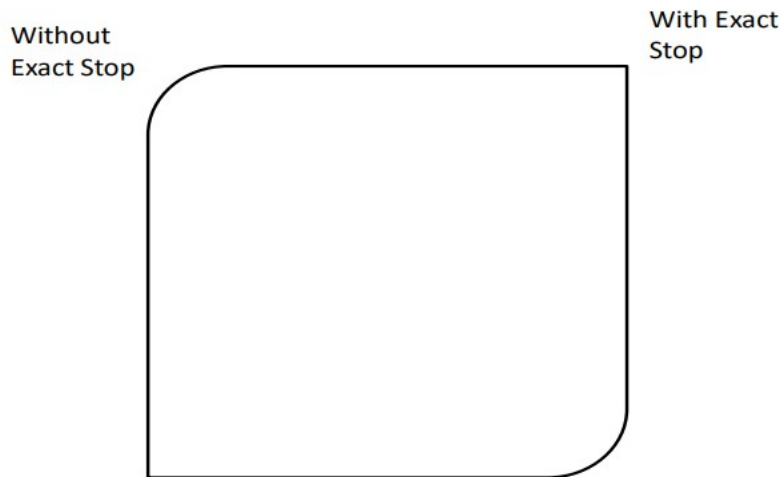

Figure 9-1: Square with exact stop on two corners

Figure 9-1 shows what this square would look like, slightly exaggerated.

G10 L1 – Tool Offset Setting

Tool offset setting with G10 L1 is a superset of the common G10 L1 used on older Fanuc controllers and it is the only way to set the X and Y offsets and wear values from a program. For compatibility with newer controls, a more modern way of setting height and diameter offsets and their respective wear offsets is provided by G10 L10, G10 L11, G10 L12, and G10 L13.

Format: G10 L1 P__ Z__ W__ D__ R__ X__ U__ Y__ V__ Q__

Or the modal version:

G10 L1

P__ Z__ W__ D__ R__ X__ U__ Y__ V__ Q__

...

G11

The multiline modal version must be canceled with G11.

L1 specifies tool offset setting, P is the offset number to be set (offset #1 = P1, offset #2 = P2, etc.). The remaining arguments specify the offset type and the value of the offset.

Z	Height offset
W	Height wear offset
D	Diameter offset
R	Diameter wear offset
X	X offset
U	X wear offset
Y	Y offset
V	Y wear offset
Q	Tool pocket

All values do not need to be specified, only the ones to be set. If, for example, a Z is not programmed it simply will not be changed in the tool offset.

In G90, absolute, mode the values in the G10 line will be directly input into the tool offset. When in G91, incremental, mode the values will be **added** to the desired tool offset. This is a major difference in functionality and care should be taken to make sure the right mode is active for the desired effect.

Example: Set height of tool offset #5 to 1.5. Add .05 to offset #2 diameter wear.

G0 G90 G54 G17 G40 G49 G80

Safe start line

G10 L1 P5 Z1.5

Set tool offset 5 height to 1.5

G91	Set incremental to add to offset
G10 L1 P2 R.05	Add .05 to tool offset #2 diameter wear
M30	Program end and rewind

Example: Modal use of G10 L1.

G0 G90 G54 G17 G40 G49 G80	Safe start line
G10 L1	Start G10 L1 sequence.
P5 Z1.5	Set tool offset 5 height to 1.5
P2 R.05	Set tool offset #2 diameter wear to .05
G11	Cancel G10 L1
M30	Program end and rewind

G10 L2 – Fixture Offset Setting

It is possible to set fixture and tool offsets in the program. This can be very useful for programming multiple fixtures that have known zero points, multi pallet machines, applying automatic compensation of tool wear, and many other situations that require changing offset values. G10 is also one of the least understood G codes and is therefore underutilized. Changing offset values in a program requires a bit of cautiousness, a mistake can easily result in ruined parts and damaged tools. When used properly however, G10 can add flexibility and safety to a program and machine, especially with automation and lights out capacity or inexperienced operators.

Starting with fixture offset setting the G10 block will look like the following:

Format: G10 L2 P__ X__ Y__ Z__ A__ B__ C__

Or the modal version:

G10 L2

P__ X__ Y__ Z__ A__ B__ C__

...

G11

The multiline modal version must be canceled with G11.

L2 is the designation for fixture offset setting. The value of P specifies which offset is being set. For the basic 6 fixture offsets P values are as follows:

Fixture offset (G__)	P__
54	1
55	2
56	3
57	4
58	5
59	6

The data for the fixture offset is set by X, Y, Z, A, B, C.

X	X axis offset
Y	Y axis offset
Z	Z axis offset
A	A axis offset
B	B axis offset
C	C axis offset

All values do not need to be specified, only the ones to be set. If, for example, a Z is not programmed it simply will not be changed in the fixture offset.

In G90, absolute, mode the values in the G10 line will be directly input into the fixture offset. When in G91, incremental, mode the values will be **added** to the desired fixture offset. This is a major difference in functionality and care should be taken to make sure the right mode is active for the desired effect.

Example: Set G56 fixture offset to X-8.0, Y-3.0, Z-5.0, A45.0 in a program.

G0 G90 G54 G17 G40 G49 G80	Safe start line
G10 L2 P3 X-8.0 Y-3.0 Z-5.0 A45.0	Set G56 fixture offset values
M30	Program end and rewind

Example: The modal version of G10 L2.

G0 G90 G54 G17 G40 G49 G80	Safe start line
G10 L2 P3 X-8.0 Y-3.0 Z-5.0 A45.0	Set G56 fixture offset values
P3 X-8.0 Y-3.0 Z-5.0 A45.0	Set G56 fixture offset values
P4 X-2.0 Y-1.0 Z-3.0 A15.0	Set G57 fixture offset values
G11	Cancel G10 L12
M30	Program end and rewind

Work shift is set using G10 L2 P0.

Example: Set Work Shift offset to X-7.0, Y-2.0, Z-3.0, A15.0 in a program.

G0 G90 G54 G17 G40 G49 G80	Safe start line
G10 L2 P0 X-7.0 Y-2.0 Z-3.0 A115.0	Set Work Shift offset values
M30	Program end and rewind

G10 L3 – Tool Life Management Setting

Tool life management data can be registered, changed, or deleted in a G code program. TLM is an Industrial only feature.

There are 3 G10 L3 program formats which provide for the following actions:

Function	Description
Delete all tool groups and register new data	Delete all existing tool group and tool data before adding new tool group and tool data. This effectively replaces the entire TLM data.
Add or change tool or group data	Add or change TLM data for a tool group.
Delete tool or group data	Delete TLM data for a tool group.
Specify the tool life count type	How tool life is counted for an individual group (time, frequency, and per cycle).
Specify the tool life value	The time (minutes) or cycle count value.

G10 L3 is always modal and multiple lines are used in the formats. All formats of G10 L3 will require G11 to cancel.

Tool groups are specified as positive integers from 1 to 999. A tool group is selected for a tool change with the T word by adding the tool cancel number (usually 100 for a machine with 99 maximum tools or 1000 for a machine with 999 maximum tools) that is defined in system variable #6810 to the desired tool group number. For example, to select a tool from group 2 on a 99 max tool machine with a tool cancel number defined as 100, specify T102.

The tool life count type is specified with a 1 (cycle count) or 2 (time). The time based life count is best suited for cutting tools that can be characterized by the amount of cutting time they can endure and still remain viable. The cycle based life count is best suited for tools that are typically used in canned cycles that can typically be characterized by the number holes or bores they can endure and still remain viable.

The tool life value is a positive integer number that specifies the life of the tool (minutes or number of cycles the tool is used). It will count up from 0 to the life count specified by the group, at which point, the tool's life will expire.

Unlike a Fanuc, the only limit to the number of tools in a tool group is the maximum tool setting for the control, which is limited to 999 tools.

G10 L3 Format 1 - Register with deleting all groups

The G10 L3 line starts the sequence. The next line specifies the group P_, the life count value L_, and the optional life count type Q_. If Q is not specified, the value of bit 2 (0 == cycle or 1 == time) in system variable #6800 will determine the life count type. The next line(s) specify the tool number T_, the optional H code for the height offset H_, and the optional D code for the diameter offset D_. If H or D is not specified, the value for T will be used. The T_ H_ D_ line may be repeated for as many tools in the group as needed. Multiple tool groups can be populated by adding a new P_ L_ line sequence with its' own following T_ H_ D_ lines. The G10 function is then canceled with G11.

Format:

G10 L3

P_ L_ [Q_]

T_ [H_] [D_]

...

G11

Example: Delete all tool group information and add new data.

G10 L3	Start the register with delete sequence (No P_ given). This will delete all preexisting TLM data.
P1 L1000 Q1	Select group 1 with a 1000 life count and a cycle based life count type.
T1	Add too1 1 to group 1 using H and D offsets from tool 1.
T2 H1 D1	Add tool 2 but use tool 1 H and D offsets.
P2 L5000 Q2	Select group 2 with a 5000 life count with a time based life count type.
T3	Add tool 3 to group 2.
T4	Add tool 4 to group 2
G11	End G10 sequence.

G10 L3 Format 2 – Add or change tool group

The G10 L3 P1 line starts the sequence. The next line specifies the group P_, the life count value L_, and the optional life count type Q_. If Q is not specified, the value of bit 2 (0 == cycle or 1 == time) in system variable #6800 will determine the life count type. If the group did not exist, it is added. If the group exists the L_ and Q_ values will be updated with the specified values. The next lines specify the tool number T_, the optional H code for the height offset H_, and the optional D code for the diameter offset D_. If H or D is not specified, the value for T will be used. If the tool did not exist in the group, the tool will be added. If the tool exists in the group, the values will be updated with the specified values. The T_ H_ D_ line may be repeated for as many tools in the group as needed. Multiple tool groups can be populated by adding a new P_ L_ line sequence with its' own following T_ H_ D_ lines. The G10 function is then canceled with G11.

Format:

```
G10 L3 P1
P_ L_ [Q_]
T_ [H_] [D_]
...
G11
```

Example: Add or change tool group information.

G10 L3 P1	Start the register or change tool group sequence.
P1 L1000 Q1	Select group 1 with a 1000 life count and a cycle based life count type. Assume that the group exists and that only the life count was updated.
T1	Add tool 1 to group 1 using H and D offsets from tool 1.
T2 H1 D1	Add tool 2 but use tool 1 H and D offsets. Assume that the tool already existed in the group, but H and D were changed.
P2 L5000 Q1	Select group 2 with a 5000 life count with a cycle based life count type. Assume that the group didn't exist therefore it will be added.
T3	Add tool 3 to group 2.
T4	Add tool 4 to group 2
G11	End G10 sequence.

G10 L3 Format 3 – Delete tool life data

The G10 L3 P2 line starts the sequence. The next line specifies the group P_ to delete. Multiple groups can be specified for deletion on the following lines as needed. The G10 function is then canceled with G11.

Format:

G10 L3 P2

P__

...

P__

...

G11

Example: Delete selected tool groups.

G10 L3 P2	Start the delete tool life data sequence.
P1	Delete group 1.
P2	Delete group 2.
G11	End G10 sequence.

G10 L10 – Geometry compensation value for H code

The H code offset can be set individually with G10 L10.

The G10 block will look like the following:

Format: G10 L10 P__ R__

Or the modal version:

G10 L10

P__ R__

...

G11

The multiline modal version must be canceled with G11.

L10 specifies setting the H code offset, P is again the offset number to be set (offset #1 = P1, offset #2 = P2, etc.). R is the offset value.

In G90, absolute, mode the values in the G10 line will be directly input into the tool offset. When in G91, incremental, mode the values will be **added** to the desired tool offset. This is a major difference in functionality and care should be taken to make sure the right mode is active for the desired effect.

G10 L11 – Wear compensation value for H code

The H code wear offset can be set individually with G10 L11.

The G10 block will look like the following:

Format: G10 L11 P__ R__

Or the modal version:

G10 L11

P__ R__

...

G11

The multiline modal version must be canceled with G11.

L11 specifies setting the H code wear offset, P is again the offset number to be set (offset #1 = P1, offset #2 = P2, etc.). R is the offset value.

In G90, absolute, mode the values in the G10 line will be directly input into the tool offset. When in G91, incremental, mode the values will be **added** to the desired tool offset. This is a major difference in functionality and care should be taken to make sure the right mode is active for the desired effect.

G10 L12 – Geometry compensation value for D code

The D code offset can be set individually with G10 L12.

The G10 block will look like the following:

Format: G10 L12 P__ R__

Or the modal version:

G10 L12

P__ R__

...

G11

The multiline modal version must be canceled with G11.

L12 specifies setting the D code offset, P is again the offset number to be set (offset #1 = P1, offset #2 = P2, etc.). R is the offset value.

In G90, absolute, mode the values in the G10 line will be directly input into the tool offset. When in G91, incremental, mode the values will be **added** to the desired tool offset. This is a major difference in functionality and care should be taken to make sure the right mode is active for the desired effect.

G10 L13 – Wear compensation value for D code

The D code wear offset can be set individually with G10 L13.

The G10 block will look like the following:

Format: G13 L11 P__ R__

Or the modal version:

G10 L13

P__ R__

...

G11

The multiline modal version must be canceled with G11.

L13 specifies setting the D code wear offset, P is again the offset number to be set (offset #1 = P1, offset #2 = P2, etc.). R is the offset value.

In G90, absolute, mode the values in the G10 line will be directly input into the tool offset. When in G91, incremental, mode the values will be **added** to the desired tool offset. This is a major difference in functionality and care should be taken to make sure the right mode is active for the desired effect.

G10 L20 – Additional Fixture Offset Setting

Additional fixture offsets, G54.1 Pxx, can also be set using G10. Setting of these offsets is the same, except it is done using L20. The legacy additional fixture offsets (see fixture offset section of this manual for more details) can still be set with G10. The following table shows the additional fixture offset P number and its corresponding G10 P number as well as the legacy offsets. Note that G54.1 P1 is the same offset as G59 P7, so G10 L20 P1 and G10 L2 P7 both set the same offset values.

Starting with additional fixture offset setting the G10 block will look like the following:

Format: G10 L20 P__ X__ Y__ Z__ A__ B__ C__

Or the modal version:

G10 L20

P__ X__ Y__ Z__ A__ B__ C__

...

G11

The multiline modal version must be canceled with G11.

G54.1 P__	G10 L20 P__	Legacy G59 P__	Legacy G10 L2 P__
1	1	7	7
2	2	8	8
3	3	9	9
-	-	-	-
-	-	-	-
-	-	-	-
248	248	254	254

Example: Set G54.1 P5 fixture offset to X3.0, Y3.4, Z-10.0 in a program.

G0 G90 G54 G17 G40 G49 G80	Safe start line
G10 L20 P5 X3.0 Y3.4 Z-10.0	Set G54.1 P5 fixture offset values
M30	Program end and rewind

Example: The modal version of G10 L20.

G0 G90 G54 G17 G40 G49 G80	Safe start line
G10 L20	Start the G10 L20 sequence
P5 X3.0 Y3.4 Z-10.0	Set G54.1 P5 fixture offset values
P6 X2.0 Y2.1 Z-8.0	Set G54.1 P6 fixture offset values
G11	Cancel G10 L20
M30	Program end and rewind

Head shift is set using G10 L20 P0. Notice the L20 for head shift. All other values are set in the same format as the other fixture offsets.

Example: Set Head Shift offset to X-3.0, Y1.5, Z-8.0 in a program.

G0 G90 G54 G17 G40 G49 G80	Safe start line
G10 L20 P0 X-3.0 Y1.5 Z-8.0	Set Head Shift offset values
M30	Program end and rewind

G10 L50 – Parameter Setting

G10 L50 enables setting machine control parameters programmatically and is modal.

Format: G10 L50

N__ R__

...

N__ R__

G11

L50 specifies parameter setting mode, N specifies the parameter number, and R specified the new parameter value. R may be entered as a decimal number or a binary number. Binary numbers are read from the highest bit to the lowest bit and must be at least 8 characters long with leading zeros, if required.

Example: Set parameter 6712 (total parts machined) to 5 via binary and then to 101 via decimal.

G10 L50	Start the parameter setting sequence.
N6012 R00000101	Set 6712 = 5. (0b0000000101 == 5)
N6012 R101	Set 6712 = 101
G11	End G10 sequence.

Parameters may be read in G code programs via the PRM[] function.

Example: Read parameter 6712 as a number and as a bit value.

#100=PRM[6012]	Read parameter 6012 into common variable #100.
#101=PRM[6012, 2]	Read bit 1 of parameter 6712 into common variable #100. If bit 2 is set, #101 will be 1, otherwise #101 will be 0.

G11 – Cancel Modal G10

To end the G10 modal state a G11 must be called. G11 should be specified on its own line. The only G10 that is always modal is G10 L3 (Tool Life Management) setting.

Format: G11

G12/G13 – Circle Interpolation

These codes are used to cut a circle using the current position as the center point. Words, I and J, define the radius of the circle and the lead-in direction. G12 will cut a circle in the clockwise direction and G13 will cut in the counterclockwise direction. It is also possible to cut a larger circular pocket by specifying Q for the start radius and P for the step over amount. This can be useful for cutting a circular pocket or an ID groove.

Format 1: G12/13 I__ J__ F__

Format 2: G12/13 I__ J__ P__ Q__

See figure 12-1 for a graphic of the motion. The current position will be the center of the circle.

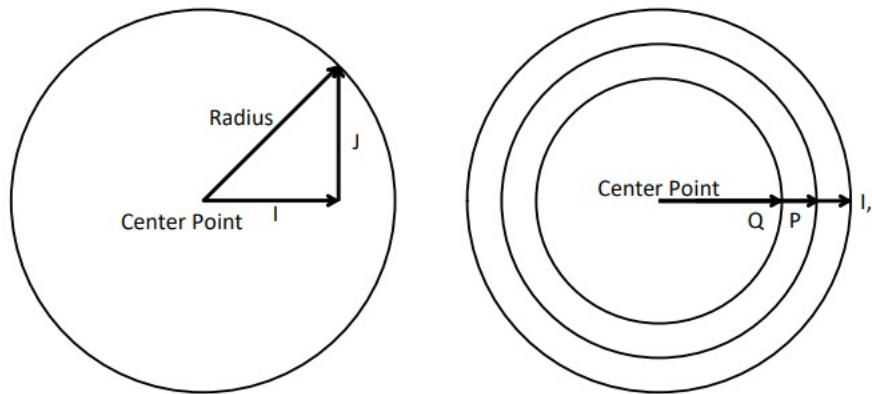

Figure 12-1: Tool motion during circle interpolation

Example: Cut a 1.0 inch radius circle centered at X1.5 Y0.25. Lead-in along the X axis.

G0 G90 G54 G17 G40 G49 G80	Safe start line, absolute mode, XY plane
G0 X1.5 Y.25	Move to initial position
G13 I1.0 F30.0	Cut circle
G0 G53 Z0.0	Z axis to machine zero
M30	Program end and rewind

Example: Cut the same circle but lead-in at 45°. ($X=1*\text{Cos}(45^\circ)=.7071$, $Y=1*\text{Sin}(45^\circ)=.7071$)

G0 G90 G54 G17 G40 G49 G80	Safe start line, absolute mode, XY plane
G0 X1.5 Y.25	Move to initial position
G13 I0.7071 J0.7071 F30.0	Cut circle
G0 G53 Z0.0	Z axis to machine zero
M30	Program end and rewind

G15/G16 – Polar Coordinates

To enable polar coordinate positioning command G16 in a program. The setting is modal and will remain active until G15, polar coordinate cancel, is commanded or the system is reset. In the polar coordinate mode movement end points are specified as a radius and angle, the origin of which is determined by the absolute/incremental position mode setting (see G90/G91). In absolute position mode the origin for positioning is the zero point of the user coordinate system. In incremental position mode the origin is the current position.

Format: G16 X__ Y__ Z__

The current plane setting determines which word is radius and which is angle.

G17 – XY Plane – X is radius, Y is angle

G18 – ZX Plane – Z is radius, X is angle

G19 – YZ Plane – Y is radius, Z is angle

Linear and arc moves can be programmed in the polar coordinate mode. When programming arc moves with G02 and G03 use R to specify the arc radius.

Example: See figure 15-1 for the tool path display of the following program.

G0 G90 G54 G17 G40 G49 G80	Safe start line, absolute mode, XY plane
G16	Enable polar coordinate mode
G0 X1.0 Y45.0	Move to radius 1 and 45° from origin
G3 X1.0 Y135.0 R0.75 F60.0	Arc move of radius .75, endpoint at radius 1.0 and angle 135°
G1 X2.25 Y180.0	Linear move to radius 2.25 angle 180°
G3 X2.25 Y0 R5.0	Arc move of radius 5., endpoint at radius 2.25, angle 0
G1 X1.0 Y45.0	Linear move to radius 1.0, angle 45°
G15	Disable polar coordinate mode
G0 G53 Z0.0	Z axis to machine zero
M30	Program end and rewind

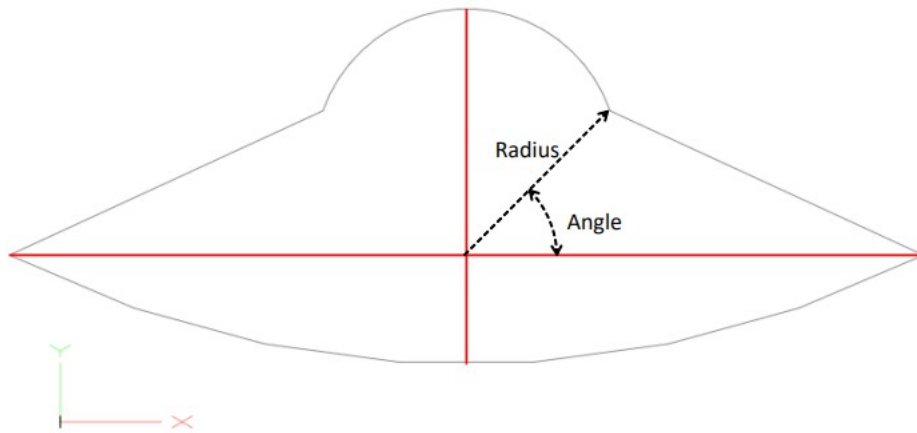

Figure 15-1: Tool path of polar coordinate mode example

G17/G18/G19 – Plane Selection

Arcs, circles and drill cycles require the selection of a plane. The three axes X, Y and Z define three available planes XY, ZX, and YZ, see figure 17-1. The third axis defines the top of the plane, this axis is also known as the normal see figure 17-2. Selection of a plane is done by specifying one of three G codes: G17 for XY, G18 for ZX and G19 for YZ. These are modal G codes and will stay active until another plane is selected or the system is reset. The default plane selection is G17.

All arc and circular motion will take place on a single plane. Direction of motion, clockwise or counterclockwise, is as viewed from the normal direction, see figure 17-2.

Canned drill cycles also require the selection of a plane. In this case all hole positions will be located in the selected plane and the normal axis will be the drilling axis. For example in the XY plane the Z axis is the drilling axis.

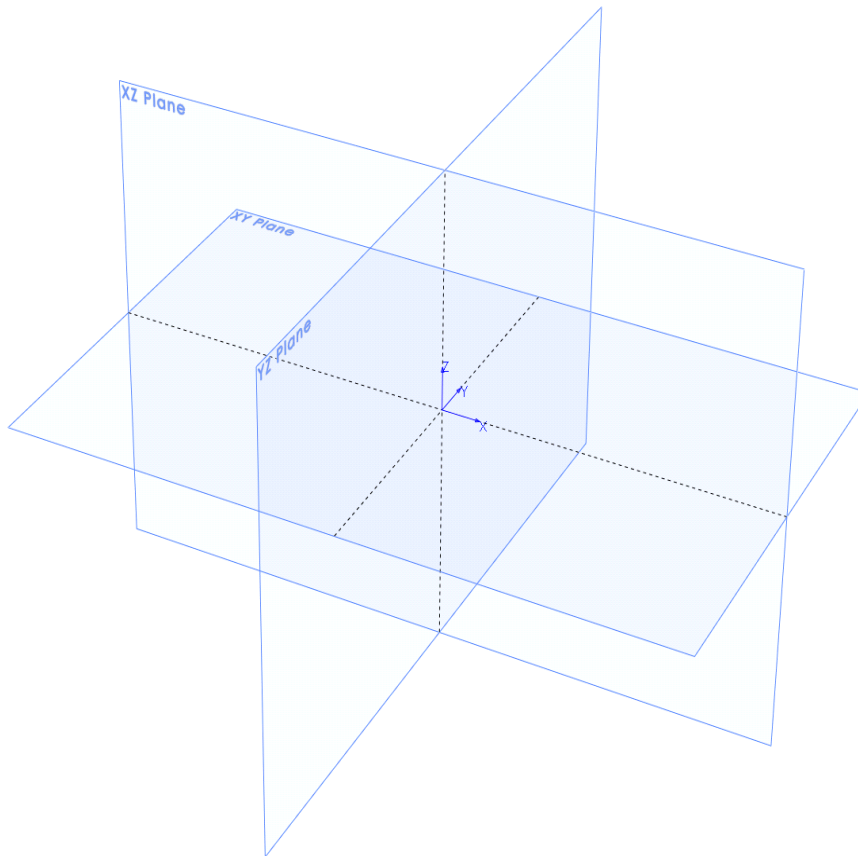

Figure 17-1: Planes

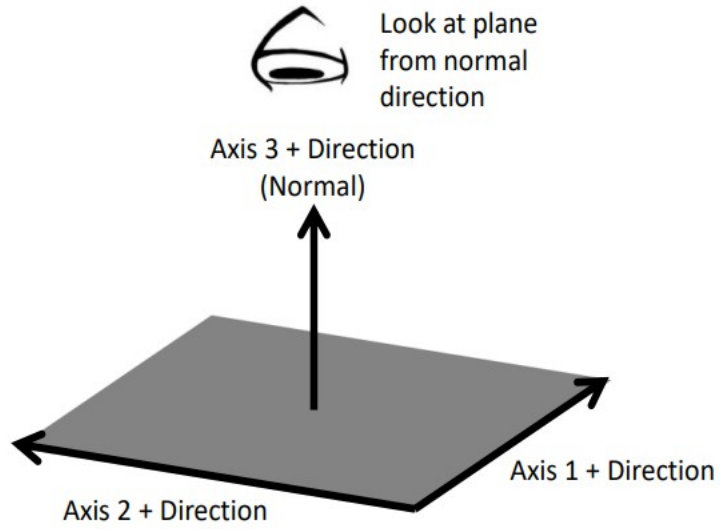

Figure 17-2: Plane orientation

G20/G21 - Unit selection

Programming units are selected using G20 for inch and G21 for millimeter. Use these G codes to specify the units in the program only; the setting will not affect Mach DRO's, configuration settings, or offsets.

G28 – Zero Return

This function is used to send one or more axes to the home position via an intermediate point. Exercise caution when using this function. If not fully understood the resulting motion may differ greatly from what is expected. When used correctly the intermediate point can be useful for avoiding obstacles in the way of a direct path to the home position, see figure 28-1.

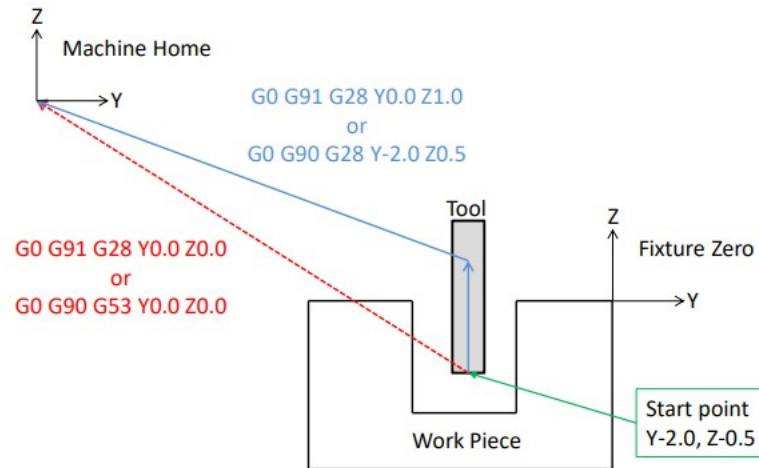

Figure 28-1: Zero return via intermediate point

Format: G28 X__ Y__ Z__ A__ B__ C__

This is not a modal code and will only be active in the block in which it is specified. Following the G28 are the axes to be sent home. For example, to send the Z axis back to the home position program: G28 Z0. The value specified with the axis letter specifies the intermediate point.

Look at an example program:

G0 G90 G54 G17 G40 G49 G80	Safe start line
G0 X1.0 Y.5 Z1.0	Rapid position to point
G28 Z0.0	Send Z axis home via point Z0
M30	Program end and rewind

Reading through the program there is a safe start up block that sets the machine to absolute position mode. The next line causes the machine to move to the point X1, Y.5, Z1. in the coordinate system set by the G54 fixture offset. Now for the G28 block. This line of code, G28 Z0, gives instructions to send the Z axis to the home position via the point Z0. The motion will be as follows: First the Z axis will plunge to the point Z0 then return to home. If not intended this motion could result in a broken tool or scrapped part. To avoid this unintended motion the common programming format is as follows:

G91 G28 Z0

In this case the intermediate point is an incremental move of 0 inches resulting in no motion before the Z axis returns home.

G28.1 – Home Axis

G28.1 physically homes the specified axes. If more than one axis is specified, then the axes are homed in order specified by the control configuration. The values of the parameters are ignored except in the case of P. If P is specified, the corresponding out of band axis is homed. Valid values for P are P6 through P11. P can only be specified once.

Format: G28.1 X__ Y__ Z__ A__ B__ C__ P__

G30 – 2nd, 3rd, 4th Zero Return

G30 functions the same way as G28, moving the machine to a zero return point via an intermediate point. However, instead of sending the machine to the home position, G30 movement ends at a user definable 2nd , 3rd, or 4th zero return point, specified by P2, P3, or P4 respectively. If P is omitted the 1st zero return point is selected. This is handy for tool changers that are not located at the home position or any number of other applications.

Format:

G30 X__ Y__ Z__ A__ B__ C__ (1st)

G30 P__ X__ Y__ Z__ A__ B__ C__ (2nd, 3rd, or 4th)

The 2nd zero return point is defined by # variables as follows:

Axis	P1 # Variables	P2 # Variables	P3 # Variables	P4 # Variables
X	5181	5351	5361	5371
Y	5182	5352	5362	5372
Z	5183	5353	5363	5373
A	5184	5354	5364	5374
B	5185	5355	5365	5375
C	5186	5356	5366	5376

The position values in the # variables can be set in a program or in MDI mode.

G31/G31.X – Probe function

Also known as skip function, G31 allows the use of part and tool probes. Multiple probes can be used, G31 for probe 1, G31.1 probe 2, G31.2 probe 3 and G31.3 probe 4. Motion is defined along linear axes, in a similar format to G01, with a feed rate.

Format: G31 X__ Y__ Z__ F__

The machine will move toward the specified end point, at the same time it is looking for the probe input to be activated. When the probe input is activated the current position is recorded to # variables according to the table below and motion is stopped. The recorded position can then be used to calculate tool offsets, work offsets, measure parts, etc.

Axis	G31 User Position Variables	G31 Machine Position Variables
X	#5061	#5071
Y	#5062	#5072
Z	#5063	#5073
A	#5064	#5074
B	#5065	#5075
C	#5066	#5076

G32 – Threading

It is possible to cut threads using a spindle to rotate the work piece and a non rotating threading tool. Equal lead straight, tapered and scroll threads can be cutting using this command. Spindle speed feedback from an encoder, index pulse, tachometer or other device is required for this operation. The syncing of the feed axis to the spindle speed creates an accurate thread; however, axis acceleration can cause variations in the thread lead especially at the start and end of the thread. The compensate program a slightly longer thread to give the axis time to accelerate. The amount of extra thread length will vary based on machine specifications. Changes in spindle speed and feed rate will impact thread quality and accuracy. Using constant surface speed mode can also result in variations in thread lead when cutting tapered or scroll threads, use G97 constant RPM mode instead. During the threading move the spindle speed and feed rate overrides will be disabled and the machine will run at 100%. Feed hold will be delayed, if pressed the machine will stop at the end of the threading move.

Format: G32 X__ Y__ Z__ F__

The G32 threading cycle is a single linear move synced to the spindle speed. F specifies the lead or pitch of the thread. For example a 20 TPI thread would have a pitch of .05 inches, so program F.05. By default the movement is basic linear move with synced feed rate. Machine builders and advanced users have the added option to create custom M codes to specify the feed vector to create custom threads.

Example: Thread a ¼-20 rod held in the spindle, 1” length of thread.

G0 G90 G54 G18 G40 G49 G80	Safe start line
G0 X0.3 Y0.0 Z0.1	Rapid position
G97 S1000 M3	Start spindle at 1000 RPM
G0 X0.22	Move to start position for rough
G32 X0.22 Z-1.0 F.05	Cut straight thread
G0 X0.3	Retract X axis
Z0.1	Retract Z axis
X0.21	Move to start position for finish
G32 X0.21 Z-1.0 F.05	Cut straight thread
G0 X0.3	Retract X axis
Z0.1	Retract Z axis
G53 Z0.0 M5	Z home and stop spindle
M30	Program end and rewind

Threads can also be cut with a taper by adding the proper end point.

Example: Cut same thread as previous example with 0.03 taper.

G0 G90 G54 G18 G40 G49 G80	Safe start line
G0 X0.3 Y0.0 Z0.1	Rapid position
G97 S1000 M3	Start spindle at 1000 RPM
G0 X0.22	Move to start position for rough
G32 X0.25 Z-1.0 F.05	Cut tapered thread
G0 X0.3	Retract X axis
Z0.1	Retract Z axis
X0.21	Move to start position for finish
G32 X0.24 Z-1.0 F.05	Cut tapered thread
G0 X0.3	Retract X axis
Z0.1	Retract Z axis
G53 Z0.0 M5	Z home and stop spindle
M30	Program end and rewind

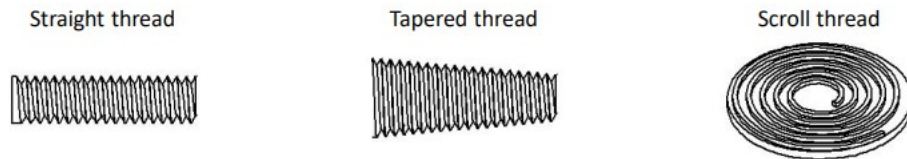

Figure 32-1: Basic thread types

G40 – Cutter Compensation Cancel

G40 cancels the cutter compensation mode.

G40.1 – Arc Type Cutter Compensation

G40.1 selects the arc type cutter compensation mode. In this mode, external corners will generate a rounded path, this provides smoother motion at high feed rates, see figure 401-1, G40.1. Cutter comp modes can be changed on the fly, figure 401-2. See the [cutter compensation](#) section of this manual for more details and limitations.

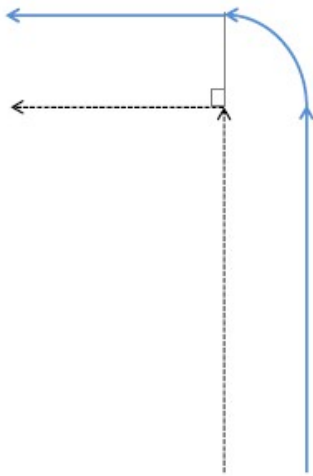

G40.1 – Arc type

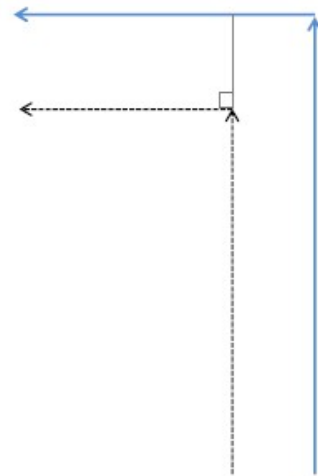

G40.2 – Line offset type

-----> Programmed tool path
 ———> Cutter comp tool path

Figure 401-1: Cutter compensation types.

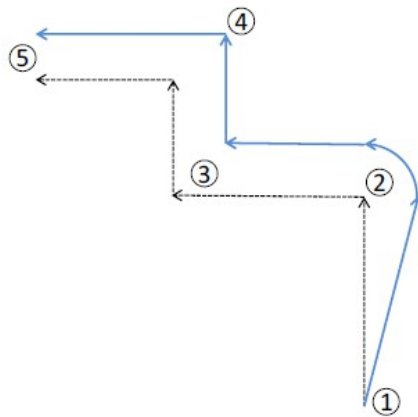

```
G00 G90 G54 G17 G40 G49 G80
① G0 X1.5 Y-.75 Z1.
S1000 M3
G1 Z-.25 F30.
G40.1
② G42 P.10 Y0
③ X.5
④ G40.2 Y1
⑤ X0
G40
G0 G53 Z0
M30
```

-----> Programmed tool path
 ———> Cutter comp tool path

Figure 401-2: G42 cutter compensation path.

G40.2 – Line Offset Type Cutter Compensation

G40.2 selects the line offset type cutter compensation mode. In this mode, external corners will generate a square path, see figure 401-1, G40.2. Cutter comp modes can be changed on the fly, figure 401-2. See the [cutter compensation](#) section of this manual for more details and limitations.

G41/G42 – Cutter Compensation Left/Right

Enables cutter compensation to the left (G41) or right (G42) of the cutter path by an amount specified in an offset selected by D.

Format: G1 G42 D__ X__ Y__ Z__ F__

For detailed information see the [cutter compensation](#) section of this manual.

G43/G44 – Tool Length Offset

Activates a tool length offset selected with H. When activated the position DROs will be updated to display the position of the program point of the tool, generally the tip. The tool offset can be applied in the positive direction with G43 or in the negative direction with G44. Generally G43 will be used to apply the tool offset. There are a number of ways of touching off a tool and determining the offset value, see tool offsets in the operation manual for more details, but they are all called and applied the same way.

Format: G43 H__ X__ Y__ Z__

If axis positions are specified in the same block as G43 the machine will move to the commanded point. If the axes are omitted there will be no motion.

G49 – Tool Length Offset Cancel

G49 cancels the tool length offset. If no motion is commanded in the G49 block there will be no motion of the machine.

G50 – Scaling Cancel

G50 cancels scaling.

G51 – Scaling/Mirroring Function

When activated the scaling function multiplies all commanded positions by the specified scale factor. The DROs and offsets are not affected, but motion commanded from a program or the MDI screen is affected.

Format: G51 X__ Y__ Z__ A__ B__ C__

Specify the axis to be scaled and the desired scale factor. For example:

G0 G90 G54 G17 G40 G49 G80	Safe start line
G0 X4.0 Y0.0 Z1.0	Rapid position to point (X position is 4.)
G51 X2.0	Activate scaling on X axis (scale factor = 2)
G0 X5.0	Rapid position to point (X position is 10.)
G50	Cancel Scaling
G0 X5.0	Rapid position to point (X position is 5.)
M30	Program end and rewind

When scaling is active position moves will be calculated by multiplying the commanded position by the scale factor. In the example above the scale factor on the X axis is set to 2, then a move to X5. is commanded. The actual end position of this move will be $5 * 2 = 10$. So the X axis moves to 10.

Exercise caution when using scaling, the results can be unpredictable depending on program complexity. For example if G52 X2 Y4 is programmed followed by an arc move in the XY plane, the arc will NOT be scaled 2x in the X axis and 4x in the Y axis to obtain an ellipse. The start and end positions will be as expected, but the motion from one to the other may not be. Check and double check the tool path display before running the program.

To mirror a program, enter a negative scale value. For example:

G0 G90 G54 G17 G40 G49 G80	Safe start line
G0 X4.0 Y0.0 Z1.0	Rapid position to point (X position is 4.)
G51 X-1.0	Mirror X axis (scale factor = 1)
G0 X5.0	Rapid position to point (X position is -5.)
G50	Cancel Scaling
G0 X5.0	Rapid position to point (X position is 5.)
M30	Program end and rewind

G52 – Local Coordinate System Shift

The local coordinate system setting is a programmable work shift. The setting is global; the entire system is shifted by the specified values. Every fixture offset will be affected, although the actual fixture offset values will not be changed.

Format: G52 X__ Y__ Z__ A__ B__ C__

To activate a local coordinate system with G52 use the above format. Setting of a local coordinate system is just like setting a fixture offset. In the G52 block specify the desired axes to set, and the value of the shift. For example (see figure 52-1 for the tool path):

G0 G90 G54 G17 G40 G49 G80	Safe start line
G0 X-4.0 Y0.0 Z1.0	Rapid position to point
G12 I2.0 F30.0	Cut circle with radius 2.0
G52 X7.0	Local Coordinate system active, X offset = 7
G0 X-4.0 Y0.0 Z1.0	Rapid to same start point
G12 I2.0 F30.0	Cut same circle with radius 2.0
G52 X0.0	Local coordinate system cancelled
M30	Program end and rewind

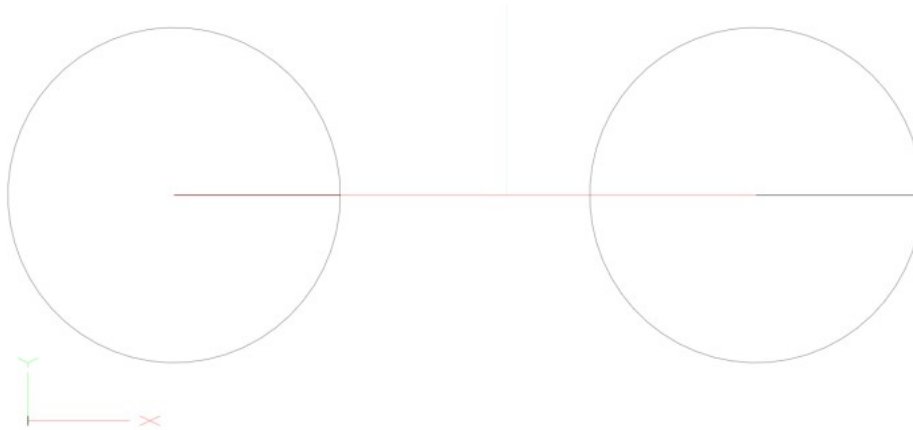

Figure 52-1: Example program tool path.

Once set, the setting will remain until cancelled by another G52 or the system is reset. As in the example above, a local coordinate system can be cancelled by specifying the axis with a value of zero. This effectively sets the local coordinate system shift to zero, giving it no effect.

G53 – Machine Coordinate System

Although the majority of machine positioning will take place in a user created coordinate system it is sometimes beneficial to program positions in the machine coordinate system. G53 is a non modal, only active for the block in which it is specified, G code that allows the user to make positioning moves in the machine coordinate system. This can be useful for moving to a load/unload position at the end of a program or moving to a tool change location in a tool change macro. This is also a much safer way to move back to the machine home position, G53 X0 Y0 Z0, than using G28 as there is no intermediate position to be concerned with.

Format: G53 X__ Y__ Z__ A__ B__ C__

G0 G90 G54 G17 G40 G49 G80	Safe start line
G0 X4.0 Y0.0 Z1.0	Rapid position in G54
...	Body of program
G53 Z0.0	Return directly to Z home position
G53 X10.0 Y0.0	Move to load/unload position
M30	Program end and rewind

In the example above, the last two positioning moves are made in the machine coordinate system. These two blocks could be the same for every program in this machine.

G54-G59 – Fixture Offset

These G codes are used to select the active fixture offset in a program. The fixture offset will stay active until another is called or the system is reset. It is possible to use multiple fixture offsets in a single program.

G54.1 – Additional Fixture Offsets

Additional fixture offsets are provided for users with many fixtures/parts/ setups. There are 248 additional offsets available.

Format: G54.1 P__

P specifies the number of the additional offset, 1 thru 248.

Previous version of Mach use G59 P7, P8 and so on. These legacy offsets can still be used in place of the G54.1. G59 P7 = G54.1 P1, G59 P8 = G54.1 P2, and so on. G54.1 is more consistent with industry machines.

Please see the fixture offset section of the Mach4 Mill Operations Guide for more detail on setting up fixture offsets.

G60 – Unidirectional Approach

In cases where mechanical backlash causes positioning errors unidirectional approach can be used to increase accuracy. G60 is a non-modal code, when specified in a movement block motion will move to the end point from a parameter defined distance and direction, see figure 60-1. The distance and direction of the approach movement is specified by setting values in # variables as shown in the following table:

Axis	# Variable
X	5440
Y	5441
Z	5442
A	5443
B	5444
C	5445

Format: G60 G0/G1 X__ Y__ Z__

When unidirectional approach is used in a drill cycle the Z axis motion is not affected. G76 and G87 boring cycles have a tool shift that is also not affected by the G60 unidirectional approach.

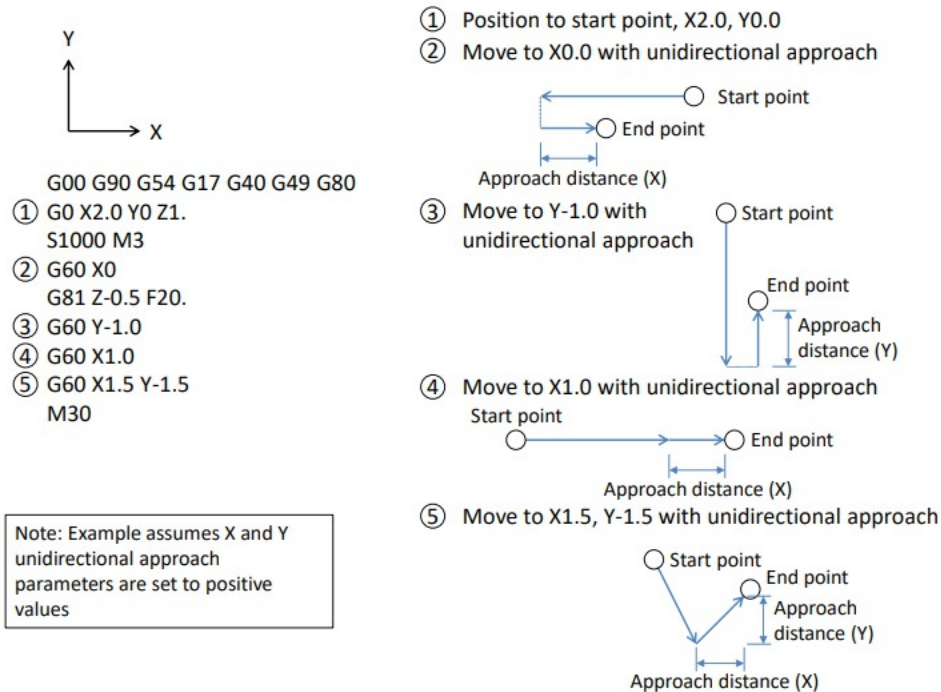

Figure 60-1: Unidirectional approach.

G61 – Exact Stop Mode

In exact stop mode the machine will decelerate to a complete stop at the end of each commanded move, see figure 9-1. This is a modal code, once activated it will remain on until canceled. For sharp corners and simple positioning this mode works well. However, when the code gets more complex, or in side milling with arcs, the exact stop mode will produce jerky motion and witness marks on the work piece. For most milling jobs use G64.

G64 – Constant Velocity Mode

In constant velocity mode Mach will try to maintain feed rate even around sharp corners. As a result sharp corners will be slightly rounded and the machine may never reach the programmed point before a direction change. The magnitude of these position errors will be determined by the acceleration capability of the machine and the programmed feed rate. In most cases the error will be too small to notice or affect part function. Cutting will be faster and smoother with better finishes and no witness marks from stopping. This will be the active mode for the majority of machining time. It is modal and will be active until exact stop mode is activated.

G65 – Macro Call

Macros work like subprograms (see M98 on page 86) but allow values to be passed from the main program in the form of local variables. Macro programs can use these local variables passed to it to change part dimensions, select features, adjust feed rates, or anything else the user could need to change.

Format: G65 P____ A__ B__ C__ ...

The desired program number to be called is specified by P. The remaining arguments are determined by the macro program being called. The values of these arguments will be passed to local variables for use in the macro program. The available arguments and corresponding variables are shown in the table below.

Address	Variable	Address	Variable	Address	Variable
A	#1	I	#4	T	#20
B	#2	J	#5	U	#21
C	#3	K	#6	V	#22
D	#7	M	#13	W	#23
E	#8	Q	#17	X	#24
F	#9	R	#18	Y	#25
H	#11	S	#19	Z	#26

The G65 macro call is non modal and has no option for repeating, the macro subprogram will be run only once per G65 call. For more information on macro programming and the availability and use of # variables see the Mach4 Macro Programming Guide.

G66 – Macro Modal Call

Sometimes it is useful to run the same macro in different positions (similar to drilling canned cycles) or with different parameters. G66 is a modal macro call, the macro is called and values passed in the same way as G65, but G66 remains active until cancelled. The block(s) following the G66 can contain new positions and variables to run the macro again.

```
Format: G66 P___ A__ B__ C__ ...  
        A__ B__ C__ ...  
        G67
```

More information on macro programming is available in the Mach4 Macro Programming Guide.

G67 – Macro Modal Call Cancel

G67 cancels the macro modal call.

G68 – Coordinate System Rotation

It is possible to rotate a program around a specified point using the coordinate system rotation command. It is specified as follows:

```
Format: G68 X__ Y__ R__
```

The command is only available in the XY (G17) plane and is modal. X and Y specify the point around which the program will be rotated, and R specifies the angle. A positive value for R will rotate the program counter clockwise when looking at the plane from the positive direction.

Once the rotation command is given, all command moves will take place in this rotated system. In effect, the X and Y axes of the machine will rotate the amount specified by R.

G0 G90 G54 G17 G40 G49 G80	Safe start line
G0 X0.0 Y0.0 Z1.0	Rapid position to point
G68 X0.0 Y0.0 R45.0	Rotate 45° counter clockwise about X0, Y0
G0 X1.0	Rapid position to X1.
G69	Cancel rotation
M30	Program end and rewind

In the example above, the machine will move to X0, Y0 then initiate the coordinate rotation of 45°. The next move is a purely X axis move to X1. However, because the coordinate system has been rotated the current X axis is actually 45° from the machine actual X axis. When the move takes place both X and Y axes will move to the programmed point. In this case the DROs will read X.7071 and Y.7071. See figure 68-1.

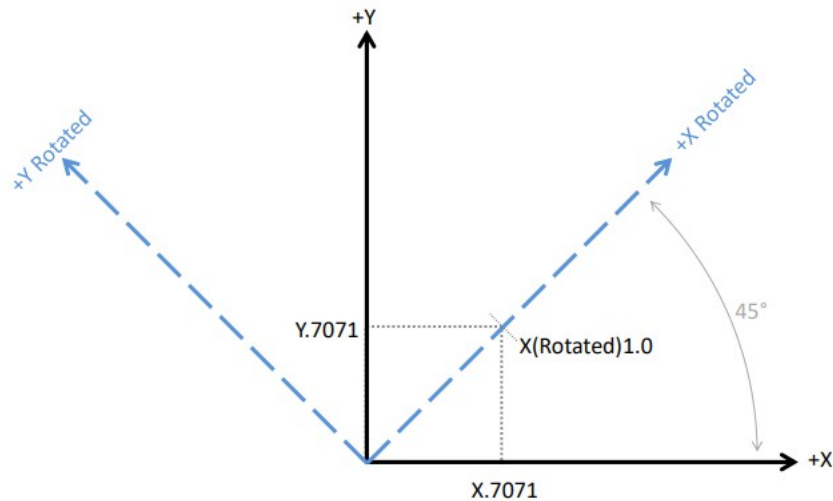

Figure 68-1: Coordinate system rotation (G68 X0 Y0 R45)

The coordinates X.7071 and Y.7071 can be proven using simple geometry or trigonometry functions.

Coordinate system rotation is useful in many applications. Combined with a part probe the function can provide a lot of power and accuracy. When probing a part to find its location, it is also possible to determine if the part is clamped square to the axes or if it is oriented at some angle. If the part is skewed at an angle it can be automatically compensated for, resulting in higher quality parts.

Limitations: In coordinate system rotation mode, G codes related to reference position return (G27, G28, G29, G30, etc...) and those for changing the coordinate system (G52 to G59, G92, etc... and including manual DRO editing of the current coordinate system) must not be specified. Correct movement will not be performed. If any of these G codes is necessary, specify it only after canceling coordinate system rotation mode.

The first move command after the coordinate system rotation cancel command (G69) must be specified with absolute values. If an incremental move command is specified, correct movement will not be performed.

By default, the coordinate system for the part is rotated but the axis position displays are not. Setting parameter 1800 to 1 will all the axis position displays to include the rotation.

G69 – Coordinate System Rotation Cancel

G69 cancels a coordinate system rotation command. The machine returns back to normal function.

G73-G89 – Canned Cycles

Canned cycles are special G codes used to simplify programming. See the [Canned Cycles](#) section of this manual for detailed information.

G code	Description	Format	Page
G73	High Speed Peck	G73 X_Y_Z_R_Q_F_	63
G74	Reverse Tapping	G74 X_Y_Z_R_F_	66
G76	Fine Boring	G76 X_Y_Z_R_I_J_P_F_ G76 X_Y_Z_R_Q_P_F_	68
G80	Canned Cycle Cancel	G80	58
G81	Drilling	G81 X_Y_Z_R_F_	59
G82	Spot Face	G82 X_Y_Z_R_P_F_	60
G83	Deep Hole Peck Drilling	G83 X_Y_Z_R_Q_F_	61
G84	Tapping	G84 X_Y_Z_R_F_	65
G85	Boring, Retract at Feed, Spindle On	G85 X_Y_Z_R_F_	70
G86	Boring, Retract at Rapid, Spindle Off	G86 X_Y_Z_R_F_	71
G87	Back Boring	G87 X_Y_Z_R_I_J_F_ G87 X_Y_Z_R_Q_F_	72
G88	Boring, Manual Retract	G88 X_Y_Z_R_P_F_	74
G89	Boring, Dwell, Retract at Feed, Spindle On	G89 X_Y_Z_R_P_F_	75

G90/G91 – Absolute/Incremental Position Mode

In absolute position mode, the machine will move to the commanded position in the active work piece coordinate system.

Example: Write a program to move to the hole positions in figure 90-1 in absolute position mode. Assume the machine starts at position X0, Y0, end the program at X0, Y0.

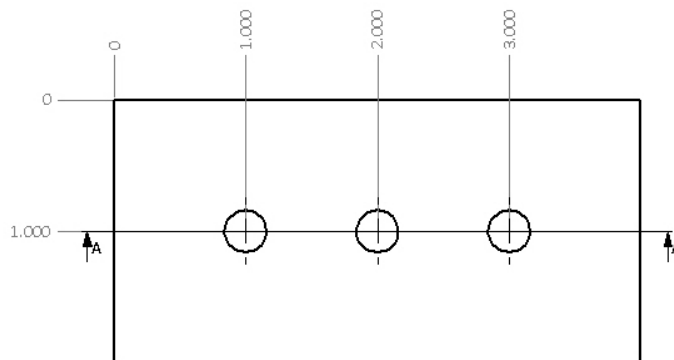

Figure 90-1: Hole pattern example

G0 G90 G54 G17 G40 G49 G80	Safe start line
G90	Absolute position mode
G0 X1.0 Y-1.0	Rapid to 1 st hole
X2.0	Rapid to 2 nd hole
X3.0	Rapid to 3 rd hole
X0.0 Y0.0	Rapid back to 0, 0
M30	Program end and rewind

In incremental position mode, commanded moves are interpreted as distance and direction from the current position. A command of X1 will move 1 in the positive direction, NOT necessarily to the point X1 in the user coordinate system.

Example: Write a program to move to the hole positions in figure 90-1 in incremental position mode. Assume the machine starts at position X0, Y0, end the program at X0, Y0.

G0 G90 G54 G17 G40 G49 G80	Safe start line
G91	Incremental position mode
G0 X1.0 Y-1.0	Rapid to 1 st hole
X1.0	Rapid to 2 nd hole
X1.0	Rapid to 3 rd hole
X-3.0 Y1.0	Rapid back to 0, 0
M30	Program end and rewind

Compare this to the program from G90. Because the starting point is X0, Y0 in both examples the move to the 1st hole is the same. However, if the machine started at X1, Y1 the absolute position program would still be correct, the incremental program would be shifted by the start location. For this reason it is important to ensure the proper mode is enabled for the program in use. A good safe start line will always contain a G90 or G91. These G codes are modal and will stay active until the other is specified.

G90.1/G91.1 – Absolute/Incremental Arc Center Mode

This setting affects arcs when programmed in the I, J, K format. In absolute arc center mode the I, J, K values designate the position of the arc center in the user coordinate system. In incremental arc center mode the I, J, K values designate the distance and direction to the arc center from the start point. See figure 2-1 for a graphical description.

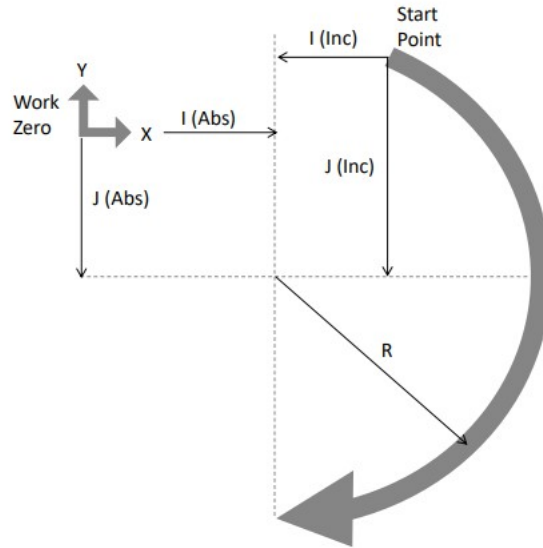

Figure 2-1: Path of tool point in circular and helical interpolation (G02).

Example: Program an arc centered at 1.0, 0.0 in the XY plane with radius 2. Start point at 3.0,0.0 and sweep 90 degrees counter clockwise. Program two times, once in incremental arc center mode and once in absolute arc center mode.

G0 G90 G54 G17 G40 G49 G80	Safe start line
G91.1	Incremental arc center mode
T1 M6	Tool change
S2500 M3	Start spindle
G0 X3.0 Y0.0	Position to X and Y start point
G43 H1 Z.5	Activate tool offset 1 and move to Z rapid plane
G1 Z0.0 F10.0	Z plunge at feed rate
G3 X1.0 Y2.0 I-2.0 J0.0 F10.0	Arc move
G0 Z.5	Retract Z to rapid plane
G0 G53 Z0.0	Return Z to home
M30	Program end and rewind

G0 G90 G54 G17 G40 G49 G80	Safe start line
G90.1	Absolute arc center mode
T1 M6	Tool change
S2500 M3	Start spindle
G0 X3.0 Y0.0	Position to X and Y start point
G43 H1 Z.5	Activate tool offset 1 and move to Z rapid plane
G1 Z0.0 F10.0	Z plunge at feed rate
G3 X1.0 Y2.0 I1.0 J0.0 F10.0	Arc move
G0 Z.5	Retract Z to rapid plane
G0 G53 Z0.0	Return Z to home
M30	Program end and rewind

Notice the difference in the I values of the example programs. Both programs will produce the same arc.

G92 – Local Coordinate System Setting

The coordinate system can be set by issuing G92 in the program. This function differs from G52 (Local Coordinate System Shift) in the way that it is specified. While G52 is specified with shift values, G92 is specified with the desired axis position. The affect is global and should be used with caution.

Format: G92 X__ Y__ Z__ A__ B__ C__

Using the above format specify a value for the desired axis. When G92 is specified the position DRO's are updated to the values specified. The local coordinate system setting will be cancelled when a G92.1 is specified or the system is reset.

G0 G90 G54 G17 G40 G49 G80	Safe start line
G0 X4.0 Y0.0 Z1.0	Rapid move, current position X4, Y0, Z1
G92 X1.0 Y2.0 Z3.0	Set local coordinate system, current position X1, Y2, Z3
G92.1	Cancel local coordinate system, current position X4, Y0, Z1
M30	Program end and rewind

G92 was used for fixture offset setting before fixture offsets were available. It is recommended that the fixture offsets be used instead of using G92. The offset amount of the G92 setting is not immediately known by the user, because of this the results can be unpredictable when fixture offsets and G92 are combined.

G93 – Inverse Time Feed

Inverse time feed is most commonly used for machine movement containing at least one rotary axis, however that is not the only application. Instead of specifying a velocity a time to complete the movement is specified. The following formula is used to determine F:

$$F = \frac{1}{\text{time (min)}} = \frac{\text{feedrate (units/min)}}{\text{distance (units)}}$$

When inverse time feed is active an F word is required in every block of code containing a feed move.

G94 – Feed Per Minute

G94 is the most common feed rate setting. Specify the desired feed rate in units/minute. In this mode the feed rate is modal and not required in all feed move blocks.

G95 – Feed Per Revolution

On mills, the feed per revolution setting is most commonly used for tapping cycles. In this mode the feed rate is specified in units/revolution of the spindle. In the case of tapping the feed rate can be set as the pitch of the tap. For every revolution of the spindle the machine will move the specified units. Feed per rev mode requires RPM feedback from the spindle.

G96 – Constant Surface Speed

Spindle speed can be specified two ways. One is constant surface speed. In this mode Mach will try to keep the surface speed constant based on cutting diameter. Surface speed is specified in surface units per minute. In the inch mode this is surface feet per minute, in millimeter mode it is surface meters per minute.

G97 – Constant RPM

In this mode the spindle speed is specified in revolutions per minute. This is the most common setting for milling machines.

G98 – Initial Point Return

G98 specifies that a canned cycle end at the initial Z level. The machine will also return to the initial point before a rapid move to the next position. Initial point return is useful for avoiding steps in parts or fixture clamps without adding a significant amount of cycle time. See figure 98-1.

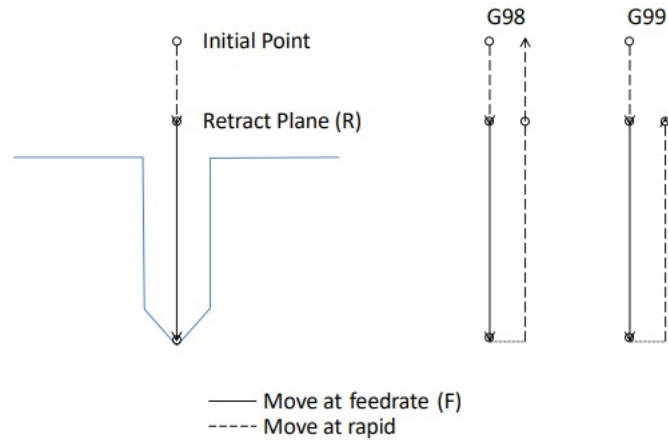

Figure 98-1: Initial and R point return setting.

G99 – R Point Return

G99 specifies that a canned cycle end at the programmed R level, see figure 98-1. When drilling holes in a flat plate, G99 can be used to reduce excessive machine movement decreasing cycle time.

Chapter 3: Canned Cycles

G73	High Speed Peck	G73 X_Y_Z_R_Q_F_
G74	Reverse Tapping	G74 X_Y_Z_R_F_
G76	Fine Boring	G76 X_Y_Z_R_I_J_P_F_ G76 X_Y_Z_R_Q_P_F_
G80	Canned Cycle Cancel	G80
G81	Drilling	G81 X_Y_Z_R_F_
G82	Spot Face	G82 X_Y_Z_R_P_F_
G83	Deep Hole Peck Drilling	G83 X_Y_Z_R_Q_F_
G84	Tapping	G84 X_Y_Z_R_F_
G85	Boring, Retract at Feed, Spindle On	G85 X_Y_Z_R_F_
G86	Boring, Retract at Rapid, Spindle Off	G86 X_Y_Z_R_F_
G87	Back Boring	G87 X_Y_Z_R_I_J_F_ G87 X_Y_Z_R_Q_F_
G88	Boring, Manual Retract	G88 X_Y_Z_R_P_F_
G89	Boring, Dwell, Retract at Feed, Spindle On	G89 X_Y_Z_R_P_F_

Canned cycles are used to reduce program complexity. For example peck drilling a 1 inch hole with .1 inch peck depth would use 30 lines of regular code, but with a canned cycle this same hole can be completed in just 2 lines of code. More importantly if multiple holes are required only 1 extra line of code per hole is needed. There are a variety of canned cycles for different hole types including drilling, boring, and tapping.

Hole machining cycles all behave similarly and mostly contain the same parameters. The meaning of each parameter can change depending on two settings. The first is the absolute or incremental mode setting (G90/G91) as defined earlier in this manual. The second is the return point selection G98 initial point return or G99 R point return.

Plane selection (G17/G18/G19) can also have an effect on hole machining cycles. Positioning will take place in the active plane, and the drilling operation will be on the normal axis. For example in G17 (XY Plane) hole position will be on the XY plane and the drilling axis will be Z. In G18 (ZX Plane) positioning will be on the ZX plane and the drilling axis will be Y. For the purposes of this manual all examples and definitions will be in the XY plane (G17).

The basic format of a canned cycle is as follows:

Gcc G98/99 Xxx Yyy Zzz Qqq Rrr Ppp Lll Fff
Xxn Yyn
G80

- cc Number of the desired canned cycle (i.e. 81, 83, 74, etc)
- xx In G90: X position of the center point of the first hole with respect to the current work zero point
In G91: Distance and direction along X axis to center point of first hole from the current position
- yy In G90: Y position of the center point of the first hole with respect to the current work zero point
In G91: Distance and direction along Y axis to center point of first hole from the current position
- zz In G90: Z position of bottom of hole with respect to the current work zero point
In G91: Distance and direction along Z axis, from point R, to bottom of hole
- qq Peck increment if deep hole drilling, always positive
- rr Retract plane, retract position between pecks, in G99 mode this is the rapid plane
- pp Dwell, in milliseconds, at bottom of hole
- ll Number of repetitions
- ff Feed rate
- xn Position of nth hole X axis, same rules as applied to xx
- yn Position of nth hole Y axis, same rules as applied to yy

Please note that not all arguments will appear in all cycles, and there are a couple special cases that will be discussed.

Figure 2: Example hole pattern

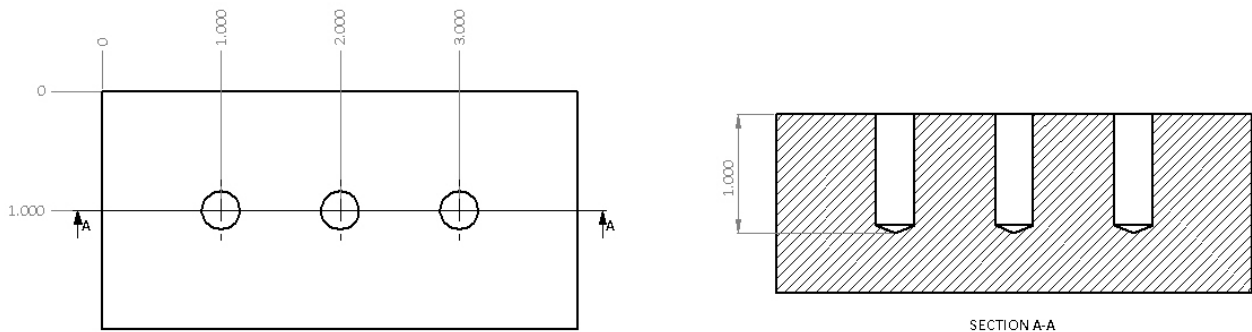

G80 – Canned Cycle Cancel

To end a canned cycle a G80 must be called. G80 should be specified on its own line to avoid any unintended movements. For example:

G0 G90 G54 G17 G40 G49 G80	Safe start line
T1 M6	Tool change
S2500 M3	Start spindle
G0 X1.0 Y-1.0	Position to X and Y start point
G43 H1 Z.5	Activate tool offset 1 and move to Z initial point
G81 G99 X1.0 Y-1.0 Z-1.0 R.25 F10	Drill cycle start
X2.0 Y-1.0	Drill second hole
X3.0 Y-1.0	Drill third hole
G80	Canned cycle cancel
G0 G53 Z0	Return Z to home
M30	Program end and rewind

Drilling

G81 – Drilling

This is a straight drilling cycle. The tool simply moves to position, feeds to the bottom of the hole then rapid retracts to either the R point or the initial point. See figure 81-1 for a graphic of the tool motion. The format is as follows:

G81 X__ Y__ Z__ R__ L__ F__

X, Y – Position of hole in XY plane

Z – End point of hole

R – Retract plane

L – Number of repetitions

F – Feed rate

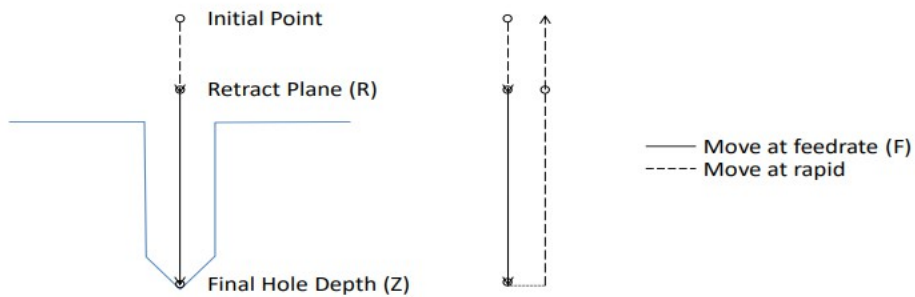

Figure 81-1: Motion of tool point for G81 cycle. End Z position will be determined by G98/99 setting.

Example: Create the program for the holes shown in Figure 2.

G0 G90 G54 G17 G40 G49 G80	Safe start line
T1 M6	Tool change
S2500 M3	Start spindle
G0 X1.0 Y-1.0	Position to X and Y start point
G43 H1 Z.5	Activate tool offset 1 and move to Z initial point
G81 G99 X1.0 Y-1.0 Z-1.0 R.25 F10	Drill cycle start
X2.0 Y-1.0	Drill second hole
X3.0 Y-1.0	Drill third hole
G80	Canned cycle cancel
G0 G53 Z0	Return Z to home
M30	Program end and rewind

G82 – Spot Face

Spot face adds the ability to dwell at the bottom of the hole for a specified amount of time. The actual tool motion is the same as a G81 cycle, however with the dwell it is possible to attain better accuracy and finish at the bottom of the hole. This is useful for chamfering, counter boring, and spot facing. The format is as follows:

G82 X__ Y__ Z__ R__ P__ L__ F__

X, Y – Position of hole in XY plane

Z – End point of hole

R – Retract plane

P – Dwell

L – Number of repetitions

F – Feed rate

Example:

Create a chamfering program for the holes shown in figure 2, dwell for .2 seconds.

G0 G90 G54 G17 G40 G49 G80	Safe start line
T1 M6	Tool change
S2500 M3	Start spindle
G0 X1.0 Y-1.0	Position to X and Y start point
G43 H1 Z.5	Activate tool offset 1 and move to Z initial point
G82 G99 X1.0 Y-1.0 Z-.200 P.2 R.25 F10	Spot drill cycle start
X2.0 Y-1.0	Drill second hole
X3.0 Y-1.0	Drill third hole
G80	Canned cycle cancel
G0 G53 Z0	Return Z to home
M30	Program end and rewind

G83 – Peck Drilling

Peck drilling is a cycle used for drilling deep holes. The cycle allows for breaking and clearing of chips and better application of coolant by fully retracting the tool from the hole between pecks. The retract amount is controlled by parameter 5115. This retract move and plunge to previous depth are rapid moves, each peck is a feed move at the specified feed rate. See figure 83-1 for a graphic of the tool motion.

Parameter 5115: Integer value 0 to 32767

Unit of Data:

Increment System	IS-B	Unit
Inch Input	0.0001	inch
Millimeter input	0.001	mm

Default: 100 (0.0100 inch) for inch machines. 250 (.25 mm) for metric machines.

The format is as follows:

G83 X__ Y__ Z__ Q__ R__ L__ F__

X, Y – Position of hole in XY plane

Z – End point of hole

Q – Peck amount

R – Retract plane

L – Number of repetitions

F – Feed rate

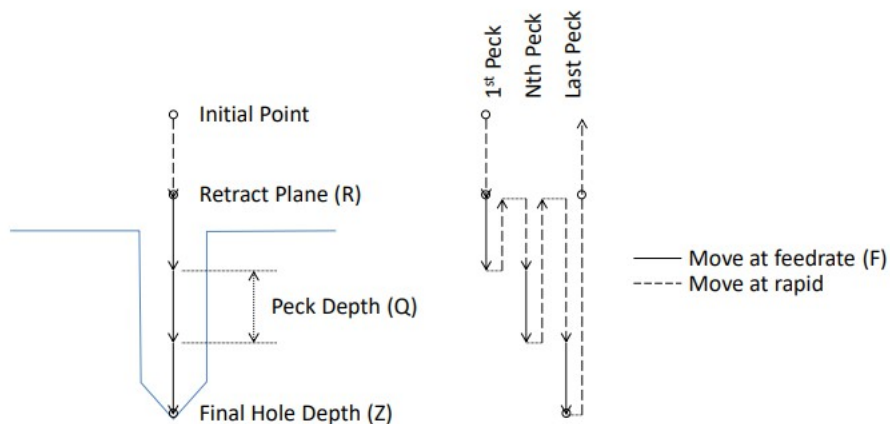

Figure 83-1: Motion of tool point for G83 cycle. End Z position will be determined by G98/99 setting.

Example:

Create the program for the holes shown in figure 2 using a .1 peck depth.

G0 G90 G54 G17 G40 G49 G80	Safe start line
T1 M6	Tool change
S2500 M3	Start spindle
G0 X1.0 Y-1.0	Position to X and Y start point
G43 H1 Z.5	Activate tool offset 1 and move to Z initial point
G83 G99 X1.0 Y-1.0 Z-1.0 Q.1 R.25 F10	Peck drill cycle start
X2.0 Y-1.0	Drill second hole
X3.0 Y-1.0	Drill third hole
G80	Canned cycle cancel
G0 G53 Z0	Return Z to home
M30	Program end and rewind

G73 – High Speed Peck

In materials that produce long stringy chips a high speed peck cycle can be used to break them up. Unlike the G83 cycle that retracts completely out of the hole after each peck, the G73 cycle only retracts by a preset amount in parameter 5114. See figure 73-1. This short retract helps to reduce cycle times when a complete retract is unnecessary.

Parameter 5114: Integer value 0 to 32767

Unit of Data:

Increment System	IS-B	Unit
Inch Input	0.0001	inch
Millimeter input	0.001	mm

Default: 250 (0.0250 inch) for inch machines. 600 (.6mm) for metric machines.

The format:

G73 X__ Y__ Z__ Q__ R__ L__ F__

X, Y – Position of hole in XY plane

Z – End point of hole

Q – Peck amount

R – Retract plane

L – Number of repetitions

F – Feed rate

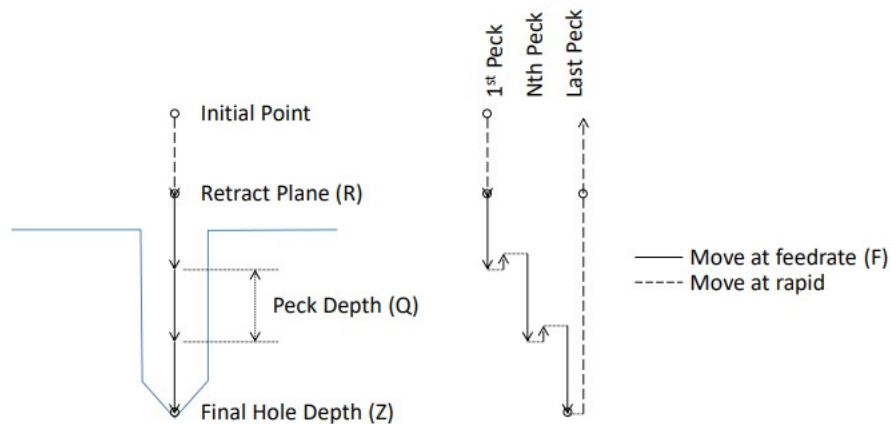

Figure 73-1: Motion of tool point for G73 cycle. End Z position will be determined by G98/99 setting.

Example:

Create the program for the holes shown in figure 2 using a .025 peck depth.

G0 G90 G54 G17 G40 G49 G80	Safe start line
T1 M6	Tool change
S2500 M3	Start spindle
G0 X1.0 Y-1.0	Position to X and Y start point
G43 H1 Z.5	Activate tool offset 1 and move to Z initial point
G73 G99 X1.0 Y-1.0 Z-1.0 Q.1 R.25 F10	Peck drill cycle start
X2.0 Y-1.0	Drill second hole
X3.0 Y-1.0	Drill third hole
G80	Canned cycle cancel
G0 G53 Z0	Return Z to home
M30	Program end and rewind

Tapping

G84 – Right Hand Tapping

The tapping cycle is used to create threaded holes using a tap. Tapping requires that the spindle rpm and Z axis feed rate be matched, related by the pitch of the thread being cut. There are two ways to achieve this synchronization of spindle speed and Z axis feed rate. From the programming side it is easier to program the feed rate in units per revolution (G95). In the feed per rev mode the commanded feed rate will be simply the pitch of the thread. Metric threads are classified with the thread pitch, i.e. M8x1.25mm thread has a 1.25mm pitch. Unified threads are classified by threads per inch which requires a bit of calculation to get the pitch, don't worry it's easy. Simply divide 1 inch by the TPI. For a ¼-20 fastener we would calculate $1/20 = .05$, this is the pitch. The catch is, to use feed per rev requires some form of rpm feedback from the machine, not every machine will have this. For the machines without feedback the tapping cycle can be programmed in feed per min mode (G94). This method requires a little more math to obtain the correct feed rate based on spindle rpm and pitch of the thread. The equation looks like this: $RPM * Pitch = IPM$. To tap that ¼-20 hole at 1500 RPM we first need to calculate the pitch, remember $1/TPI = Pitch$, so $1/20 = .05$. Now we calculate the feed per min as $1500 * .05 = 75$ IPM. It is important to note that if the spindle speed is changed, the feed per minute must also be changed to match. Now that the math is done, check out the format of the code:

```
G84 X__ Y__ Z__ R__ L__ F__
```

X, Y – Position of hole in XY plane

Z – End point of hole

R – Retract plane

L – Number of repetitions

F – Feed rate

The motion of the tapping cycle is straight forward, but does require some additional description. See Figure 84-1 for a graphic of the tool motion. The movement is very similar to a straight drill cycle, action of the spindle being the major difference. The spindle must be started in the forward direction prior to calling the G84 cycle. The machine will then move to the hole position then the Z axis will move down to the R plane. The Z will feed down to the specified depth then the spindle and Z axis will stop then reverse direction to retract out of the hole. Due to slight variations of spindle speed, feed rate and accelerations in some machines it is recommended that a special tapping head be used. A tapping head allows the tap to float a little bit, compensating for those variations, especially at the bottom of the hole.

Changes to feed rate or spindle speed mid cycle can be damaging to the tool and work piece, for this reason the feed rate and spindle speed overrides are disabled. The machine will run at 100% override for the duration of the cycle. Feed hold is also disabled during the cycle. If feed hold is pressed motion will stop at the end of the tapping cycle.

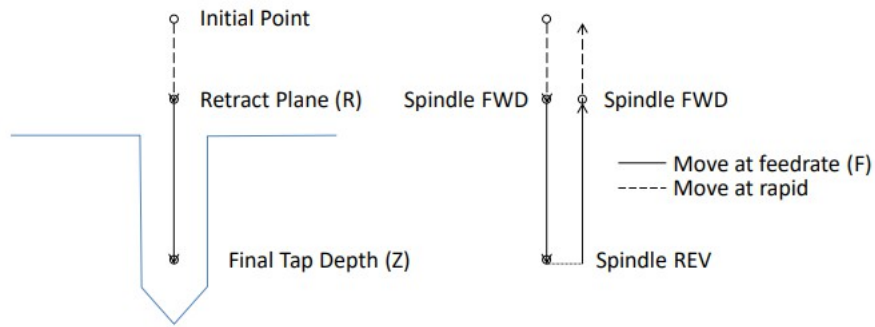

Figure 84-1: Motion of tool point for G84 cycle. End Z position will be determined by G98/99 setting.

Example:

Create the program to tap the holes shown in figure 2 to a depth of .500 with a 3/8-16 tap using feed/min.

$$1/16 = .0625$$

$$1000 * .0625 = 62.5$$

G0 G90 G54 G17 G40 G49 G80	Safe start line
T1 M6	Tool change
S1000 M3	Start spindle
G0 X1.0 Y-1.0	Position to X and Y start point
G43 H1 Z.5	Activate tool offset 1 and move to Z initial point
G84 G99 X1.0 Y-1.0 Z-.500 R.25 F62.5	Tapping cycle start
X2.0 Y-1.0	Tap second hole
X3.0 Y-1.0	Tap third hole
G80	Canned cycle cancel
G0 G53 Z0	Return Z to home
M30	Program end and rewind

G74 - Left Hand Tapping

Left hand tapping is the same as right hand tapping (G84) except that it will cut left hand threads. The spindle must be started in the reverse direction before calling the G74 cycle.

G84.2/G84.3 – Right and Left Hand Rigid Tapping

Rigid tapping can be performed on capable machines. As the name implies the tap is held rigidly in the spindle, no tension/compression style tapping holder is required. Holding the tap in this manner requires the machine to have precise control of spindle speed, axis feed, and precise feedback of spindle RPM. The tapping axis will be electronically geared to the spindle RPM. Use G84.2 for right hand tapping and G84.3 for left hand tapping. See figure 84-1 for a graphic of the motion.

Format: G84.2/84.3 X__ Y__ Z__ R__ P__ L__ F__ J__

X, Y – Position of hole in XY plane

Z – End point of hole

R – Retract plane

P – Dwell in milliseconds

L – Number of repetitions

F – Feed rate

J – Spindle speed for retract

As will other tapping cycles the feed rate and spindle speed overrides are disabled and set to 100% for the duration of the cycle. Feed hold is also no effective until the end of the tapping cycle.

Example:

Create the program to tap the holes shown in figure 2 to a depth of .500 with a 3/8-16 tap using feed/min. Tap at 1000 RPM, retract at 2000 RPM

$1/16 = .0625$

$1000 * .0625 = 62.5$

G0 G90 G54 G17 G40 G49 G80	Safe start line
T1 M6	Tool change
S1000 M3	Start spindle
G0 X1.0 Y-1.0	Position to X and Y start point
G43 H1 Z.5	Activate tool offset 1 and move to Z initial point
G84.2 G99 X1.0 Y-1.0 Z-.500 R.25 F62.5 J2000	Rigid tapping cycle start
X2.0 Y-1.0	Tap second hole
X3.0 Y-1.0	Tap third hole
G80	Canned cycle cancel
G0 G53 Z0	Return Z to home
M30	Program end and rewind

Boring

G76 – Fine Boring

The fine boring cycle allows the user to stop the spindle and move the tool away from the wall before retracting. This allows for a rapid retract without leaving a scratch on the wall.

```
G76 X__ Y__ Z__ R__ I__ J__ P__ L__ F__
```

or

```
G76 X__ Y__ Z__ R__ Q__ P__ L__ F__
```

X, Y – Position of hole in XY plane

Z – End point of hole

R – Retract plane

I – X shift distance and direction

J – Y shift distance and direction

Q – Shift distance (Always positive. Direction and axis are defined by bits 5 and 4 in parameter 5101)

P – Dwell in milliseconds

L – Number of repetitions

F – Feed rate

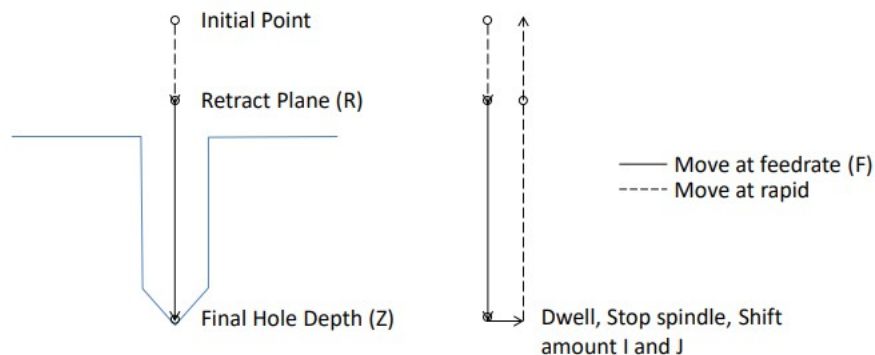

Figure 76-1: Motion of tool point for G76 cycle. End Z position will be determined by G98/99 setting.

After feeding to the bottom of the hole, the machine will pause for the specified dwell time, then the spindle will stop in the orient position before making the shift move defined by I and J. In machines with a spindle orient function called by M19 this will all be automatic. However, many machines are not capable of orienting the spindle so the orientation must be done manually. Because of the vast variety of machines that handle spindle orientation differently, the spindleorient.mcs script controls how the spindle is oriented, automatically or manually. If the machine is not capable of automatic spindle orientation, the spindle orient script should command a spindle stop and a mandatory program stop.

This will allow the operator to manually orient the spindle before the shift move is made. Here is an example of the spindleorient.mcs macro for the manual orient:

```

function spindleorient(orientation, direction)
  local inst = mc.mcGetInstance() -- Get the current instance
  local rc = mc.mcCntlWaitOnCycleStart(inst, "Press Cycle Start when the spindle is oriented.", 0)
  if rc ~= mc.MERROR_NOERROR then
    mc.mcCntlSetLastError(inst, "Spindle Orient Error")
  return
  end
end

if (mc.mclnEditor() == 1) then
  spindleorient(0.0, 1)
end

```

Example:

Create the program to fine bore the holes shown in figure 2.

G0 G90 G54 G17 G40 G49 G80	Safe start line
T1 M6	Tool change
S2500 M3	Start spindle
G0 X1.0 Y-1.0	Position to X and Y start point
G43 H1 Z.5	Activate tool offset 1 and move to Z initial point
G76 G99 X1.0 Y-1.0 Z-1.0 R.25 I-.025 J0 F10.0	Fine bore cycle, shift X-.025 at bottom
X2.0 Y-1.0	Bore second hole
X3.0 Y-1.0	Bore third hole
G80	Canned cycle cancel
G0 G53 Z0	Return Z to home
M30	Program end and rewind

G85 – Boring, Feed rate Retract

G85 is a straight boring cycle, most commonly used for boring or reaming. The retract is at the programmed feed rate with the spindle on.

G85 X__ Y__ Z__ R__ L__ F__

X, Y – Position of hole in XY plane

Z – End point of hole

R – Retract plane

L – Number of repetitions

F – Feed rate

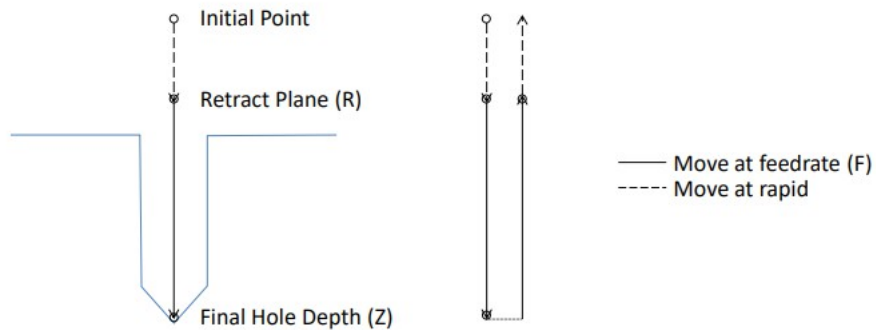

Figure 85-1: Motion of tool point for G85 cycle. End Z position will be determined by G98/99 setting.

Example:

Create the program to bore the holes shown in figure 2.

G0 G90 G54 G17 G40 G49 G80	Safe start line
T1 M6	Tool change
S2500 M3	Start spindle
G0 X1.0 Y-1.0	Position to X and Y start point
G43 H1 Z.5	Activate tool offset 1 and move to Z initial point
G85 G99 X1.0 Y-1.0 Z-1.0 R.25 F10.0	Boring cycle start
X2.0 Y-1.0	Bore second hole
X3.0 Y-1.0	Bore third hole
G80	Canned cycle cancel
G0 G53 Z0	Return Z to home
M30	Program end and rewind

G86 – Boring, Rapid Retract

G86 is a straight boring cycle. Before retracting from the hole the spindle is stopped. The retract is then performed at the rapid rate. This will leave a scratch or multiple scratches where the cutting edges are in contact with the wall.

G86 X__ Y__ Z__ R__ P__ L__ F__

X, Y – Position of hole in XY plane

Z – End point of hole

R – Retract plane

P – Dwell in milliseconds

L – Number of repetitions

F – Feed rate

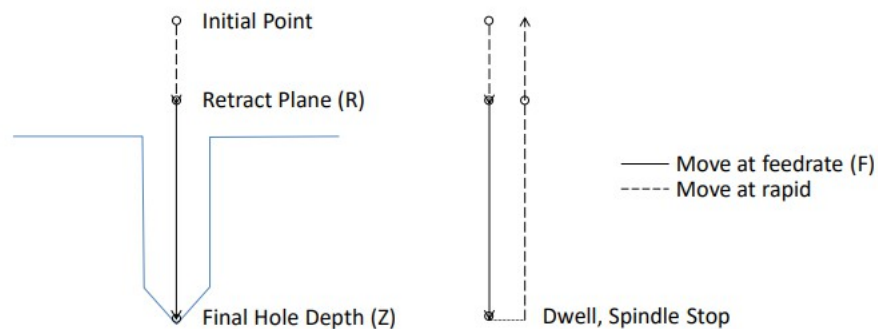

Figure 86-1: Motion of tool point for G86 cycle. End Z position will be determined by G98/99 setting.

Example: Create the program to bore the holes shown in figure 2.

G0 G90 G54 G17 G40 G49 G80	Safe start line
T1 M6	Tool change
S2500 M3	Start spindle
G0 X1.0 Y-1.0	Position to X and Y start point
G43 H1 Z.5	Activate tool offset 1 and move to Z initial point
G86 G99 X1.0 Y-1.0 Z-1.0 R.25 F10.0	Boring cycle start
X2.0 Y-1.0	Bore second hole
X3.0 Y-1.0	Bore third hole
G80	Canned cycle cancel
G0 G53 Z0	Return Z to home
M30	Program end and rewind

G87 – Back Boring

G87 is a back boring cycle. This is a useful cycle for spot facing, counter boring or chamfering the back side of a part. At the start of the cycle the spindle will be stopped at the orient position and the tool

offset from the hole center by the distance and direction defined by I and J. For machines that do not have the ability to orient the spindle, see the M19 macro example in the G76 cycle description. The tool can then be positioned to the R point below the work piece. Once at the R point the tool will be positioned at the hole center and the spindle started to perform the back boring operation. When the specified Z point is reached the machine will orient the spindle, offset by amount I, J and retract back to the initial point. In this cycle the R point will always be below the work piece, not a good point the end the cycle. For that reason this canned cycle will always return to the initial point, it is not possible to specify a G99 R point return.

G87 X__ Y__ Z__ R__ I__ J__ P__ L__ F__

G87 X__ Y__ Z__ R__ Q__ P__ L__ F__

X, Y – Position of hole in XY plane

Z – End point of hole

R – Retract plane

I – X shift distance and direction

J – Y shift distance and direction

Q – Shift distance (Always positive. Direction and axis are defined by bits 5 and 4 in parameter 5101)

P – Dwell in milliseconds

L – Number of repetitions

F – Feed rate

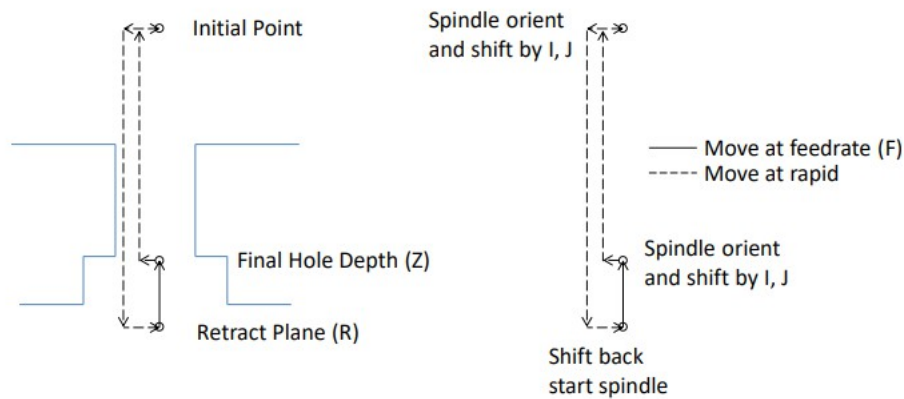

Figure 87-1: Motion of tool point for G87 cycle. End Z position will be determined by G98/99 setting.

Example:

Create the program to back bore thru holes at the same positions shown in figure 2. Thru depth 1 inch, back bore depth .150 inch.

G0 G90 G54 G17 G40 G49 G80	Safe start line
T1 M6	Tool change
S2500 M3	Start spindle
G0 X1.0 Y-1.0	Position to X and Y start point
G43 H1 Z.5	Activate tool offset 1 and move to Z initial point
G87 G98 X1.0 Y-1.0 Z-0.85 R-1.05 I-.10 F10.0	Back boring cycle start (Shift -.1 in X axis)
X2.0 Y-1.0	Bore second hole
X3.0 Y-1.0	Bore third hole
G80	Canned cycle cancel
G0 G53 Z0	Return Z to home
M30	Program end and rewind

G88 – Boring, Manual Retract

This boring cycle features a manual retract. At the bottom of the hole the specified dwell is performed, then the spindle is stopped and the program paused. The operator can then manually retract the tool from the hole. After retracting the tool cycle start is pressed to continue program operation.

G88 X__ Y__ Z__ R__ P__ L__ F__

X, Y – Position of hole in XY plane

Z – End point of hole

R – Retract plane

P – Dwell in milliseconds

L – Number of repetitions

F – Feed rate

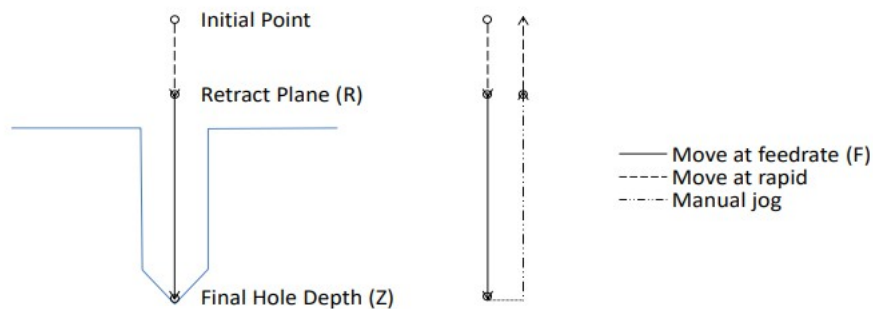

Figure 88-1: Motion of tool point for G85 cycle.

Example:

Create the program to bore the holes shown in figure 2.

G0 G90 G54 G17 G40 G49 G80	Safe start line
T1 M6	Tool change
S2500 M3	Start spindle
G0 X1.0 Y-1.0	Position to X and Y start point
G43 H1 Z.5	Activate tool offset 1 and move to Z initial point
G88 G99 X1.0 Y-1.0 Z-1.0 R.25 F10.0	Boring cycle start, pause for manual retract
X2.0 Y-1.0	Bore second hole, pause for manual retract
X3.0 Y-1.0	Bore third hole, pause for manual retract
G80	Canned cycle cancel
G0 G53 Z0	Return Z to home
M30	Program end and rewind

G89 – Boring, Dwell & Feed rate Retract

Same function as G85 with the addition of a dwell at the bottom of the hole.

G89 X__ Y__ Z__ R__ P__ L__ F__

X, Y – Position of hole in XY plane

Z – End point of hole

R – Retract plane

P – Dwell in milliseconds

L – Number of repetitions

F – Feed rate

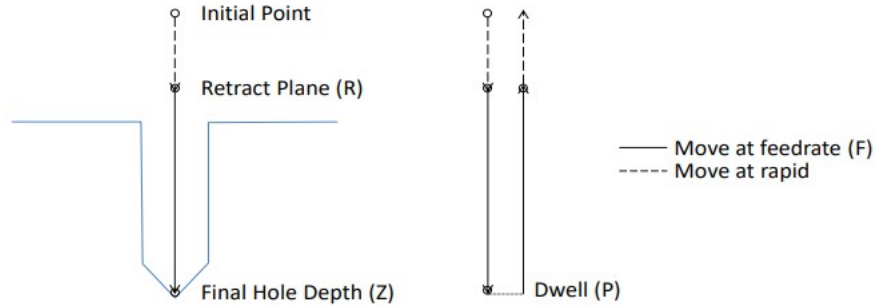

Figure 89-1: Motion of tool point for G89 cycle. End Z position will be determined by G98/99 setting.

Example:

Create the program to bore the holes shown in figure 2.

G0 G90 G54 G17 G40 G49 G80	Safe start line
T1 M6	Tool change
S2500 M3	Start spindle
G0 X1.0 Y-1.0	Position to X and Y start point
G43 H1 Z.5	Activate tool offset 1 and move to Z initial point
G89 G99 X1.0 Y-1.0 Z-1.0 R.25 P.250 F10.0	Boring cycle start
X2.0 Y-1.0	Bore second hole
X3.0 Y-1.0	Bore third hole
G80	Canned cycle cancel
G0 G53 Z0	Return Z to home
M30	Program end and rewind

Chapter 4: Cutter Compensation

Cutter compensation provides the user with the ability to adjust the tool path for variations in tool cutter diameter. It can be used in two ways. First, when programming by hand, without the aid of CAM (Computer Aided Manufacturing) software, it is much easier to program the actual part dimensions, part line programming. This saves the programmer from having to calculate the correct path at the center of the tool when the edge is doing the cutting. When given a proper diameter offset, cutter compensation will make the appropriate tool path adjustments to cut the part correctly. Essentially the machine does the math for the programmer. Second, with the more widespread use of CAM systems the tool path is already adjusted for the tool diameter and the part should, in theory, be cut perfectly to size. In practice however, there are many factors that determine the finished size of a machined part, cutter and machine deflection, machine positioning accuracy, cutter diameter variations, etc. Cutter compensation allows for fine tuning the tool path, and adjustment of part dimensions, without having to change the program itself.

There are two G codes used to enable cutter compensation. G41 offsets the tool to the left of the tool path and G42 offsets the tool to the right of the tool path. This is only true for positive diameter offset values. If negative offset is specified the offset direction will be reversed, see figure 41-1. There are two ways to call the offset value with G41 and G42.

Format 1: G00/G01 G41/G42 D__ X__ Y__ F__

Format 2: G00/G01 G41/G42 P__ X__ Y__ F__

Use D to call a diameter offset from a specific tool offset number. For example, D2 will use the diameter offset value of tool offset number 2. An alternative is to use P. The value specified with P will be the actual offset value. For example, P.05 will offset the tool path .05 to the left or right.

Cutter compensation only works on the two in plane axes, so for G17 (XY plane) the X and Y axes are affected by the comp, G18 ZX and G19 YZ.

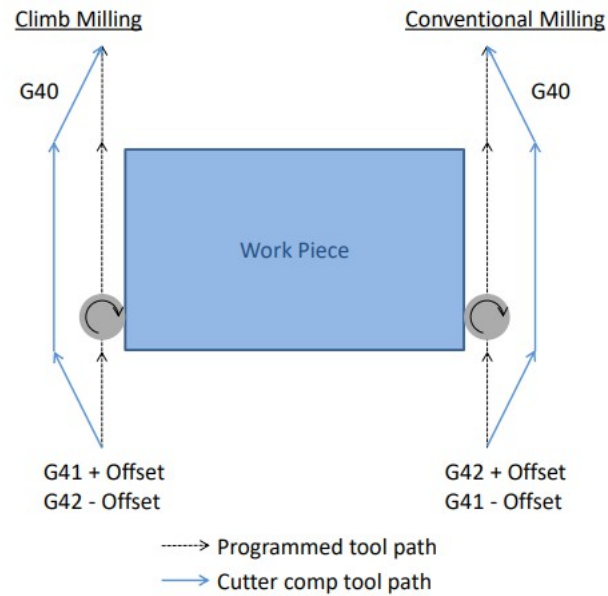

Figure 41-1: Cutter compensation offset direction.

There are two types of milling, which style is used determines how the tool should be compensated. The two types are climb milling and conventional milling, see figure 41-1. Conventional milling is the standard in manual machines, but with CNC it is possible and recommended to climb mill when possible. This manual will assume the tool will always be climb milling. With that assumption if G41 is used for outside features, the profile of a part, then a positive offset will make the part bigger and a negative offset will make the part smaller. For inside features, a hole, G42 will make the hole bigger with a positive offset and smaller with a negative offset, see figure 41-2. This method tends to make the offset values more intuitive for the operator. If conventional milling is used, this description will be reversed.

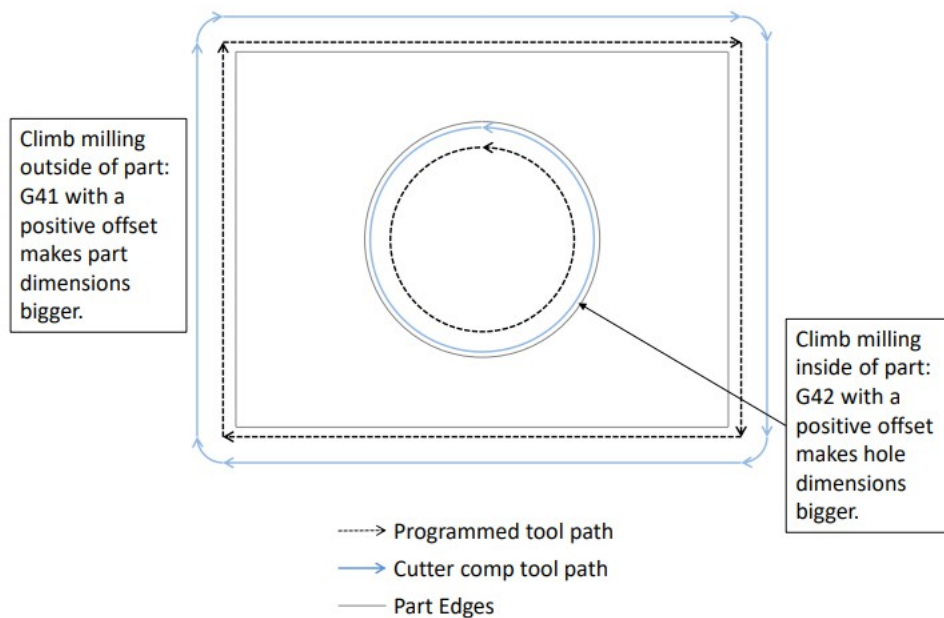

Figure 41-2: Cutter compensation OD and ID features.

Cutter comp should be enabled on a linear lead-in move; an error will be produced if cutter comp is enabled in a block with an arc. If there is a value other than zero in the offset then this lead-in move may not be parallel to the programmed path, see figure 41-1, 41-6 and 41-7. The end point of the start block is the point at a 90° angle to the movement in the next block and at the offset distance. See figure 41-3 for examples. This linear move must be longer than the offset amount, if it is not there will be an error. Also, if there are any segments of the tool path shorter than the offset amount a gouge is likely, see figure 41-4. The tool path display in Mach will display the actual tool path with comp, check to make sure there are no gouges or abnormalities before running a part.

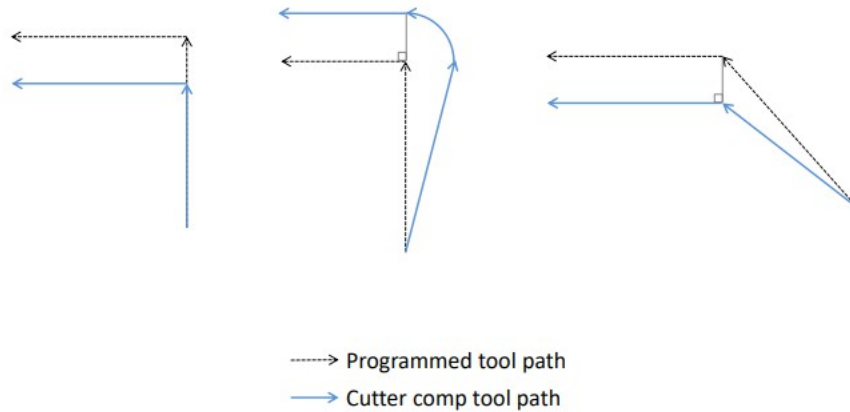

Figure 41-3: Cutter compensation start blocks.

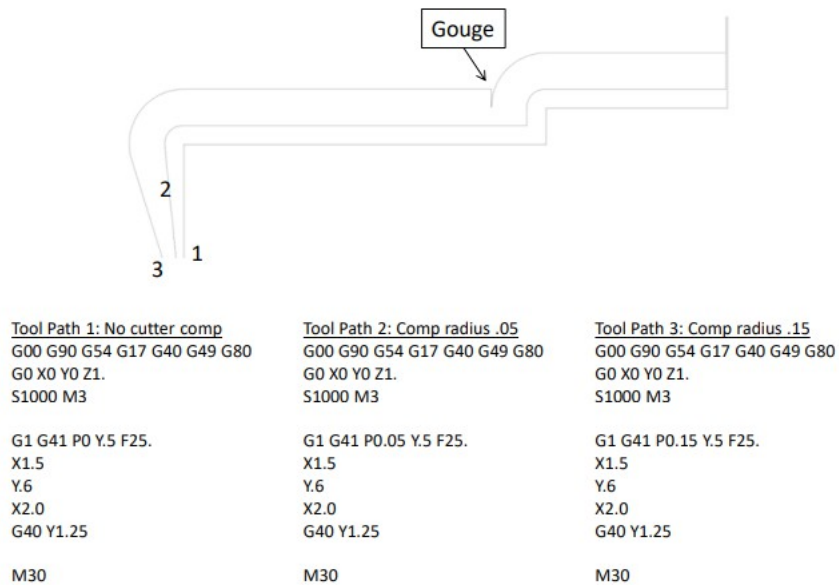

Figure 41-4: Cutter compensation radius and gouge.

Figure 41-4 shows three tool paths generated by the same program with different cutter compensation offset values. The gouge is created when an offset value greater than the step of .10 is input. When this happens the compensated tool path over laps and is reversed, causing a gouge. Another example of this is in small grooves as shown in figure 41-5.

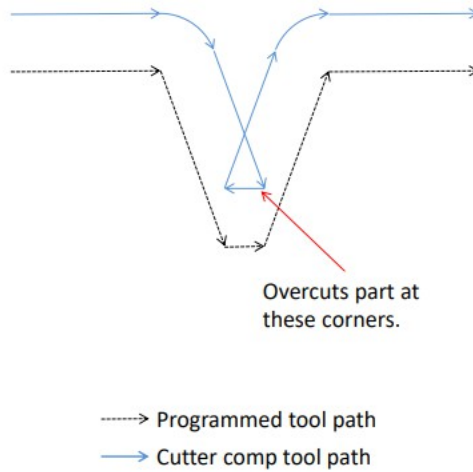
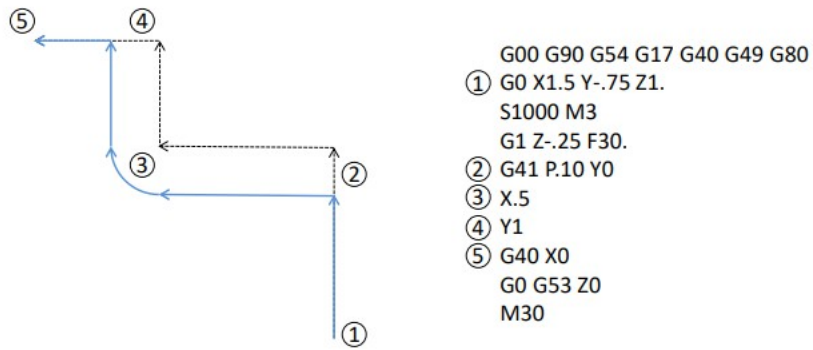

Figure 41-5: Cutter compensation in narrow groove.

Cutter compensation is cancelled by specifying G40 in the program, or when the control is reset. When G40 is specified it should be on a lead-out move following the same rules as when compensation is enabled. The path will be determined as shown in figure 41-3. Errors will occur if the lead-out distance is smaller than the offset amount or if G40 is specified on a block containing an arc move.



-----> Programmed tool path
 ———> Cutter comp tool path

Figure 41-6: G41 cutter compensation path.

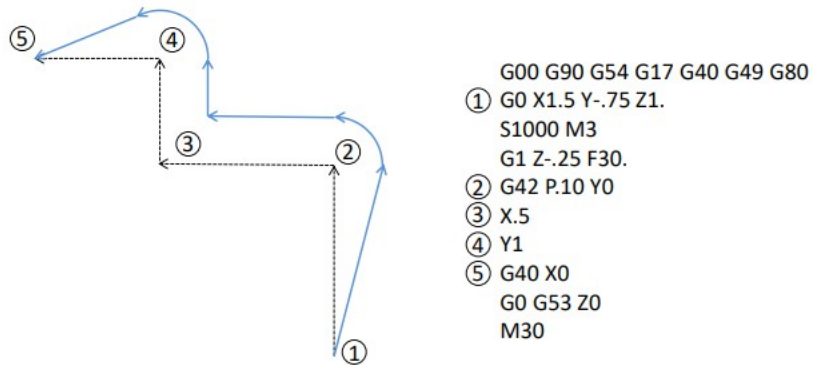

-----> Programmed tool path
 ———> Cutter comp tool path

Figure 41-7: G42 cutter compensation path.

Chapter 5: M Code List

Code	Description	Page
M00	Mandatory Program Stop	82
M01	Optional Program Stop	82
M02	Program End	82
M03	Spindle Forward/Clockwise	83
M04	Spindle Reverse/Counterclockwise	83
M05	Spindle Stop	83
M06	Tool Change	83
M07	Mist Coolant On	83
M08	Flood Coolant On	83
M09	All Coolant Off	84
M19	Spindle Orient	84
M30	Program End and Rewind	84
M48	Enable Feed/Speed Overrides	84
M49	Disable Feed/Speed Overrides	84
M62	Synchronized Output On	84
M63	Synchronized Output Off	84
M64	Immediate Output On	84
M65	Immediate Output Off	85
M66	Wait For Input	85
M98	Subprogram Call	86
M99	Return From Subprogram / Rewind	88
M???	Custom Macro M Codes	88

M Code Descriptions

M00 – Mandatory Program Stop

To pause a program at any point, specify M00. All motion will be halted and the spindle stopped. To resume operation press the cycle start button.

M01 – Optional Program Stop

The program pauses same as M00, but only when the optional stop switch is turned on. This allows the operator to stop and check program points when needed, but also to run without stops.

M02 – Program End

M02 ends the program. All program operation will be ended and defaults (G54, G17, G90, etc.) reset. The program will not rewind and if the cycle start button is pressed program operation will begin with the next block following the M02.

M03 – Spindle Forward/Clockwise

M03 starts the spindle in the forward direction at the designated speed. M03 is usually combined with an S word to define the speed. If an S word is not specified the last spindle speed is used.

M04 – Spindle Reverse/Counterclockwise

M04 starts the spindle in the reverse direction at the designated speed. M04 is usually combined with an S word to define the speed. If an S word is not specified the last spindle speed is used.

M05 – Spindle Stop

Stops spindle rotation.

M06 – Tool Change

M06 starts a tool change operation to change to the tool number specified by T. The T word can specify if the tool is the “tool to use” or the “next tool”. This is configured in the control parameters. Typically, for a carousel type tool changer, the tool specified by T on the M06 would be the tool to use. On the other hand, if the tool changer has a preload “tool arm”, then the tool specified by T on the M6 line is the next tool.

If T on M06 line is the “tool to use”, T must appear in the same block as the M06 or above it in the program. For example:

G0 G90 G54 G17 G40 G49 G80	Safe start line
G0 X4.0 Y0.0 Z1.0 T1	Rapid move, pre call tool 1
M6	Tool change to tool 1
G0 X10.0 Y-5.0 Z1.0	Rapid move
T2 M6	Tool change to tool 2
M30	Program end and rewind

If T on M06 line is the “next tool”, the “tool to use” T must appear above the M6 block and the T in the same block as the M06 is the “next tool”. For example:

G0 G90 G54 G17 G40 G49 G80	Safe start line
T1	Preload T1
G0 X4.0 Y0.0 Z1.0	Rapid move
M6 T2	Tool change to tool 1, preload T2
G0 X10.0 Y-5.0 Z1.0	Rapid move
M6	Tool change to tool 2
M30	Program end and rewind

M07 – Mist Coolant On

Turns on the mist coolant output.

M08 – Flood Coolant On

Turns on the flood coolant output.

M09 – All Coolant Off

Turns off all coolant outputs.

M19 – Spindle Orient

Although this code is not built into Mach and is completely user defined, it is required to orient the spindle for some machining cycles, G76 and G87 for example. Tool changers usually will require a spindle orientation, and although this orientation could be any M code defined by the user or even built into the M6, M19 is recommended as it is an industry standard M code. Usually, it would call the spindleorient.mcs macro

M30 – Program End and Rewind

Ends the current program and rewinds back to the beginning. Pressing the cycle start button will start program execution from the first block. All defaults (G54, G17, G90, etc.) will be reset.

M48 – Enable Feed rate/Spindle Speed Overrides

Enables the feed rate and spindle speed overrides after an M49 has been issued.

M49 – Disable Feed rate/Spindle Speed Overrides

Disables the feed rate and spindle speed overrides. This can be beneficial in production environments and also in programs or macros that are sensitive to feed rate and spindle speed by preventing accidental overrides.

M62 – Synchronized Output On

Turns on an output synchronized with the start of the next motion command. If no motion is commanded, the output will not turn on. It is best to specify motion immediately following the M62 command.

Format: M62 P__

P specifies the output number to turn on. For example: Output0 = 0, Output3 = 3, Output10 = 10, etc.

M63 – Synchronized Output Off

Turns off an output synchronized with the start of the next motion command. If no motion is commanded, the output will not turn off. It is best to specify motion immediately following the M63 command.

Format: M63 P__

P specifies the output number to turn off. For example: Output0 = 0, Output3 = 3, Output10 = 10, etc.

M64 – Immediate Output On

The specified output is turned on immediately.

Format: M64 P__

P specifies the output number to turn on. For example: Output0 = 0, Output3 = 3, Output10 = 10, etc.

M65 – Immediate Output Off

The specified output is turned off immediately.

Format: M65 P__

P specifies the output number to turn on. For example: Output0 = 0, Output3 = 3, Output10 = 10, etc.

M66 – Wait for Input

When specified, program execution will be paused until the selected input is activated. There are 5 wait modes:

- Mode 0: No wait. Current state of the input is written to #5399: low = 0, high = 1.
- Mode 1: Wait for the input to change state from low to high. If the input is high when called, the program will wait until the input goes low, then back to high.
- Mode 2: Wait for the input to change state from high to low. If the input is low when called, the program will wait until the input goes high, then back to low.
- Mode 3: Wait until the input is in the high state. If the input is high when called, the program will immediately continue.
- Mode 4: Wait until the input is in the low state. If the input low when called, the program will immediately continue.

Format: M66 P__ L__ Q__

P specifies the desired input number. For example: Input0 = 0, Input4 = 4, Input12 = 12, etc.

L specifies the mode, 0 thru 4.

Q specifies how long to wait, in seconds, for the input. If the mode is not satisfied in the specified time then #5399 will be set to -1.0 and program execution will continue.

M67 – Synchronized Analog Output

Sets the analog output synchronized with motion. This M code does not break the CV blending. The output will be set at the next motion command.

Formant: M67 E__ Q__

E specifies the analog output number (0 to 63).

Q specifies the analog value in volts.

M68 – Analog Output Immediate

Sets the analog output. This M code will break CV motion blending.

Format: M67 E__ Q__

E specifies the analog output number (0 to 63).

Q specifies the analog value in volts.

M98 – Subprogram Call

Subprograms are external programs referenced by the current running program. When called program execution will continue in the subprogram. This allows the user to reduce program length and complexity by providing the ability to easily repeat sections of code, run the same section of code in multiple locations or in multiple fixture offsets, the possibilities are limited only by the programmer. To call a subprogram command M98 with the program number as shown.

Format: M98 P____ Q__ L__

P specifies the number of the program to be called. This is a four digit integer number. When the M98 is read Mach scans the current file for a block containing the program number in the following form:

Format: O1234

Note that the letter “O” is used to specify the program number 1234, NOT the number “0”. Program execution will continue with the block following the O number. For this method the subprogram should be below the end of the current program:

(MAIN PROGRAM)	Main program header
G0 G90 G54 G17 G40 G49 G80	Safe start line
G0 X4.0 Y0.0 Z1.0	Rapid move
T1 M6	Tool change to tool 1
G0 X10.0 Y-5.0 Z1.0	Rapid move
M98 P1000	Call subprogram number 1000
M30	Program end and rewind
O1000 (SUB PROGRAM BEGIN)	Subprogram number
G12 I-0.25	Cut circle
M99	Return to main program

There are limitations to this method; mainly the subprogram must be pasted into every program that it is to be called from. Mach also allows a subprogram to be called from an external file. This way, multiple programs can call the same subprogram, without having the program in the main file. If a change needs to be made to the subprogram it only needs to be done in one file, not every file in which the sub is called. If the control does not find the program number in the current file it will then search for it in the Mach4\Subroutines directory. This time it will be searching filenames. The files in this directory should be named with the program number as follows:

Format: O____

Note the letter “O” followed by four numbers, and no file extension; O1234 not O1234.txt. When the program is loaded this file will be found and loaded into the memory, the tool path display will reflect what is in the subprogram. When running the file the M98 block will be read and program execution will continue with the first block of the subprogram file.

The arguments **Q** and **L** are optional. **Q** specifies the sequence number in the subprogram to start at. If **Q** is omitted then execution will start at the beginning of the sub program; see figure 198-1. **L** is the number of repetitions. For example, if L=2 the subprogram is run two times before execution of the main program continues. If **L** is omitted the program will run only once.

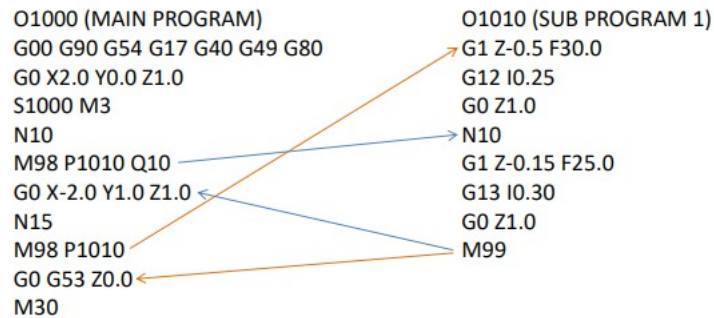

Figure 198-1: Subprogram call

M99 – Return From Subprogram / Rerun

To return to the main program from a subprogram an M99 is used.

Format: M99 P__

M99 specified in a subprogram will return to the main program at the block immediately following the M98 subprogram call. The addition of a P in the M99 block will return to a desired sequence number in the main program. See figure 199-1.

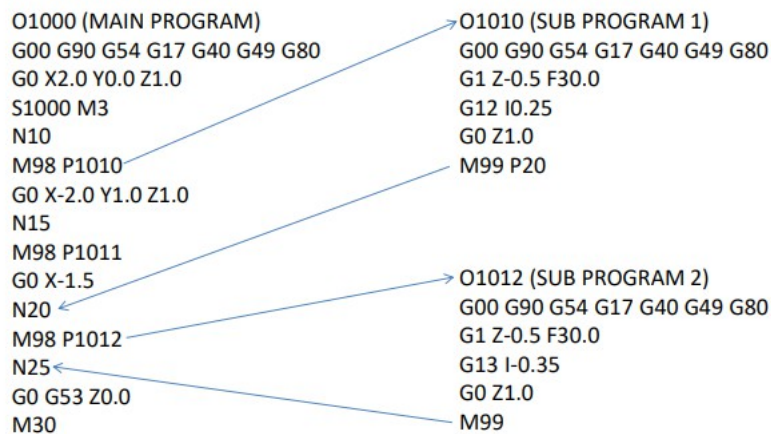

Figure 199-1: Return from sub program

If M99 is specified in a main program (not in a subprogram) a program rewind is performed. Execution will continue from the first block of the program.

Custom M Codes

Every machine is a little different and has different functions and options. Custom M codes allow the user to create simple programming calls for complex processes, activating or deactivating outputs, reading inputs, performing math, or whatever else the user and machine could require. These M codes are programmed in Lua and placed in the macros folder under each profile. Every profile can have its own unique set of M codes. The file name must be the macro to be called. For example to make a tool change macro, M6, add a Lua script with the filename M6.mcs to the macros folder in the desired profile. When an M6 is called in a program or in MDI the macro will be executed.

Chapter 6: Custom Macro

Parts of this chapter are taken from Fanuc documentation. Parametric G code programs are possible with custom macro programming. The term custom macro defines anything that is not literal NC code.

Example:

G90 G0 X10	Regular NC code. Rapid to X10
G0 X#150	Custom macro. Rapid move X to the location specified by #150.

Variables

An ordinary machining program specifies a G code and the travel distance directly with a numeric value; examples are G100 and X100.0.

With a custom macro, numeric values can be specified directly or using a variable number. When a variable number is used, the variable value can be changed by a program or using operations on the MDI panel.

Example:

#100=#2+200	Set #100 equal to the contents of #2 plus 200.
G0 X#100	Rapid move X to the location specified by #100.

- **Variable representation**

When specifying a variable, specify a number sign (#) followed by a variable number.

Example: #1

An expression can be used to specify a variable number. In such a case, the expression must be enclosed in brackets.

Example: #[#1+#2-12]

- **Types of variables**

Variables are classified into four types by variable number.

Variable number	Type of variable	Function
#0	Always null (NIL)	This variable is always NIL. No value can be assigned to this variable.
#1 – #33	Local variables	Local variables can only be used within a macro to hold data such as the results of operations. When the power is turned off, local variables are initialized to null. When a macro is called, arguments are assigned to local variables.
#100 – #149 (#199) #500 – #531 (#999)	Common variables	Common variables can be shared among different macro programs. When the power is turned off, variables #100 to #149 are initialized to null. Variables #500 to #531 hold data even when the power is removed.
#1000 –	System variables	System variables are used to read and write a variety of NC data items such as the current position and tool compensation values.

- **Referencing variables**

To reference the value of a variable in a program, specify a word address followed by the variable number. When an expression is used to specify a variable, enclose the expression in brackets.

Example: G01X[#1+#2]F#3

To reverse the sign of a referenced variable value, prefix a minus sign (–) to #.

Example: G00X–#1

- **Common variables (multi-instance/path)**

For multi-path/instance controls, macro variables are provided for each path. Some common variables, however, can be used for both paths, by setting parameters No. 6036 and 6037 accordingly.

- **Undefined variables**

When the value of a variable is not defined, such a variable is referred to as a “NIL” variable. Variable #0 is always a null variable. It cannot be written to, but it can be read.

When an undefined variable is quoted, the address itself is also ignored.

Example: When #1 is 0 and #2 is null, the result of executing G00X#1 Y#2 will be the same as when G00 X0 is executed.

System Variables

System variables can be used to read and write internal NC data such as tool compensation values and current position data. Note, however, that some system variables can only be read. System variables are essential for automation and general-purpose program development.

- **Interface signals**

Signals can be exchanged between the hardware inputs and outputs and custom macros.

Variable Number	Function
#1000–#1031 #1032	32 input signals can be mapped to hardware inputs that can be read as macro variables. Variables #1000 to #1031 are used to read the status of an input. 1 is high, 0 is low. These system variables are read only. Variable #1032 is used to read all 32 inputs at one time.
#1100–#1131 #1132	32 output signals can be mapped to hardware outputs that can be set as macro variables. Variables #1100 to #1131 are used to set the status of an output. 1 is high, 0 is low. These system variables can be read and written. Variable #1132 is used to set all 32 outputs at one time.

- **Tool compensation values**

Tool compensation values can be read and written using system variables. The control uses the tool compensation Type C memory layout.

Compensation number	Tool length compensation (H)		Cutter compensation (D)
	Geometric compensation	Wear compensation	Geometric compensation
1	#11001	#10001	#13001
⋮	⋮	⋮	⋮
501	#11501	#10501	#13501
⋮	⋮	⋮	⋮
999	#11999	#10999	#13999

- **Macro alarm**

Variable number	Function
#3000	When a value is assigned to variable #3000, the control stops with an alarm. After the expression, an alarm message can be described in a comment. Example: #3000=19 (M19 Failure!) Alarm conditions must be cleared by a control reset.

- **Macro stop**

Variable number	Function
#3006	When a value is assigned to variable #3006, the control stops (without an alarm). After the expression, an alarm message can be described in a comment. Example: #3006=21 (Oil Level Low!)

- **Time information**

Variable number	Function
#3001	This variable functions as a timer that counts in 1–millisecond increments at all times. When the power is turned on, the value of this variable is reset to 0. When 2147483648 milliseconds is reached, the value of this timer returns to 0.
#3002	This variable functions as a timer that counts in 1–hour increments when the cycle start lamp is on. This timer preserves its value even when the power is turned off. When 9544.371767 hours is reached, the value of this timer returns to 0.
#3011	This variable can be used to read the current date (year/month/day). Year/month/day information is converted to an ISO date format. For example, February 21, 2011 is represented as 20110221.
#3012	This variable can be used to read the current time (hours/minutes/seconds). Hours/minutes/seconds information is converted to a 24 hour ISO time format. For example, 12 minutes and 43 seconds after 3 p.m. is represented as 151243.

- **Number of machine parts**

The number (target number) of parts required and the number (completed number) of machined parts can be read and written.

Variable number	Function
#3901	Number of machined parts (completed number)
#3902	Number of required parts (target number)

- **Modal information**

Modal information specified in blocks up to the immediately preceding block can be read.

Variable number	Function
#4001	G00, G01, G02, G03, G33 (Group 01)
#4002	G17, G18, G19 (Group 02)
#4003	G90, G91 (Group 03)
#4004	(Group 04)
#4005	G94, G95 (Group 05)
#4006	G20, G21 (Group 06)
#4007	G40, G41, G42 (Group 07)
#4008	G43, G44, G49 (Group 08)
#4009	G73, G74, G76, G80–G89 (Group 09)
#4010	G98, G99 (Group 10)
#4011	G50, G51 (Group 11)
#4012	G66, G67 (Group 12)
#4013	G96, G97 (Group 13)
#4014	G54–G59 (Group 14)
#4015	G61–G64 (Group 15)
#4016	G68, G69 (Group 16)
:	::
#4022	(Group 22)
#4102	B code
#4107	D code
#4109	F code
#4111	H code
#4113	M code
#4114	Sequence number
#4115	Program number
#4119	S code
#4120	T code
#4130	P code (number of the currently selected additional work piece coordinate system)

Example:

When #1=#4001; is executed, the resulting value in #1 is 0, 1, 2, 3, or 33.

- **Current Position**

Position information cannot be written but can be read. The ranges are for 6 axes of information.

Variable number	Position information	Coordinate system
#4140–#4145	Origin Offset	Machine coordinate system
#5001–#5006	Block end point	Workpiece coordinate system
#5021–#5026	Current position	Machine coordinate system
#5030–#5035	Axis offset	
#5041–#5046	Current position	Workpiece coordinate system
#5050–#5045	G92.3 offset	
#5061–#5066	Skip signal position	Workpiece coordinate system
#5071–#5076	Skip signal position	Machine coordinate system
#5081–#5086	Head shift offset	
#5157	Programmed X (comp)	Workpiece coordinate system
#5158	Programmed Y (comp)	Workpiece coordinate system
#5159	Programmed Z (comp)	Workpiece coordinate system
#5181–#5286	G30 Positions	Workpiece coordinate system

The tool position where the skip signal is turned on in a G31 (skip function) block is held in variables #5061 to #5066. When the skip signal is not turned on in a G31 block, the end point of the specified block is held in these variables.

- **Workpiece coordinate system values (fixture offsets)**

Fixture offsets values can be read and written.

Variable number	Function
#5201 :	First-axis external workpiece zero point offset value (Work shift)
#5206 :	Fourth-axis external workpiece zero point offset value (Work shift)
#5221 :	First-axis G54 workpiece zero point offset value
#5226 :	Fourth-axis G54 workpiece zero point offset value
#5241 :	First-axis G55 workpiece zero point offset value
#5246 :	Fourth-axis G55 workpiece zero point offset value
#5261 :	First-axis G56 workpiece zero point offset value
#5266 :	Fourth-axis G56 workpiece zero point offset value
#5281 :	First-axis G57 workpiece zero point offset value
#5286 :	Fourth-axis G57 workpiece zero point offset value
#5301 :	First-axis G58 workpiece zero point offset value
#5306 :	Fourth-axis G58 workpiece zero point offset value
#5321 :	First-axis G59 workpiece zero point offset value
#5326 :	Fourth-axis G59 workpiece zero point offset value
#7001 :	First-axis workpiece zero point offset value (G54.1 P1)
#7006 :	Fourth-axis workpiece zero point offset value
#7021 :	First-axis workpiece zero point offset value (G54.1 P2)
#7026 :	Fourth-axis workpiece zero point offset value
#7981 :	First-axis workpiece zero point offset value (G54.1 P50)
#7986 :	Fourth-axis workpiece zero point offset value
#8001 :	First-axis workpiece zero point offset value (G54.1 P51)
#8006 :	Fourth-axis workpiece zero point offset value
#7021 :	First-axis workpiece zero point offset value (G54.1 P52)
#7026 :	Fourth-axis workpiece zero point offset value
#7981 :	First-axis workpiece zero point offset value (G54.1 P100)
#7986 :	Fourth-axis workpiece zero point offset value

The following variables can also be used for fixture offsets:

Axis	Function	Variable number
X axis	External workpiece zero point offset (Work shift) G54 workpiece zero point offset G55 workpiece zero point offset G56 workpiece zero point offset G57 workpiece zero point offset G58 workpiece zero point offset G59 workpiece zero point offset	#2500 #2501 #2502 #2503 #2504 #2505 #2506
Y axis	External workpiece zero point offset (Work shift) G54 workpiece zero point offset G55 workpiece zero point offset G56 workpiece zero point offset G57 workpiece zero point offset G58 workpiece zero point offset G59 workpiece zero point offset	#2600 #2601 #2602 #2603 #2604 #2605 #2606
Z axis	External workpiece zero point offset (Work shift) G54 workpiece zero point offset G55 workpiece zero point offset G56 workpiece zero point offset G57 workpiece zero point offset G58 workpiece zero point offset G59 workpiece zero point offset	#2700 #2701 #2702 #2703 #2704 #2705 #2706
A axis	External workpiece zero point offset (Work shift) G54 workpiece zero point offset G55 workpiece zero point offset G56 workpiece zero point offset G57 workpiece zero point offset G58 workpiece zero point offset G59 workpiece zero point offset	#2800 #2801 #2802 #2803 #2804 #2805 #2806
B axis	External workpiece zero point offset (Work shift) G54 workpiece zero point offset G55 workpiece zero point offset G56 workpiece zero point offset G57 workpiece zero point offset G58 workpiece zero point offset G59 workpiece zero point offset	#2900 #2901 #2902 #2903 #2904 #2905 #2906

Arithmetic and Logic

The operations listed in the following table can be performed on variables. The expression to the right of the operator can contain constants and/or variables combined by a function or operator. Variables #j and #k in an expression can be replaced with a constant. Variables on the left can also be replaced with an expression.

Function	Format	Comments
Definition	#i=#j	
Sum	#i=#j+#k	
Difference	#i=#j-#k	
Product	#i=#j*#k	
Quotient	#i=#j/#k	
Sine	#i=SIN[#j]	An angle is specified in degrees. 45 degrees and 15 minutes is represented as 45.25 degrees.
Arcsine	#i=ASIN[#j]	
Cosine	#i=COS[#j]	
Arccosine	#i=ACOS[#j]	
Tangent	#i=TAN[#j]	
Arctangent	#i=ATAN[#j]/[#k] or #i=ATAN[#j]	
Square root	#i=SQRT[#j]	
Absolute value	#i=ABS[#j]	
Rounding off	#i=ROUND[#j]	
Rounding down	#i=FIX[#j]	
Rounding up	#i=FUP[#j]	
Natural logarithm	#i=LN[#j]	
Exponential function	#i=EXP[#j]	
Modulus	#i=MOD[#j]	
OR	#i=#j OR #k	A logical operation is performed on binary numbers bit by bit.
XOR	#i=#j XOR #k	
AND	#i=#j AND #k	
Conversion from BCD to BIN	#i=BIN[#j]	
Conversion from BIN to BCD	#i=BCD[#j]	
Read parameter value	#i=PRM[#j]	If the whole parameter address is to be read, only #j need to be specified. To read a bit of the parameter, specify the parameter address with #j and the bit number with #k.
Read parameter bit	#i=PRM[#j, #k]	

- **Abbreviations**

When a function is specified in a program, the first two characters of the function name can be used to specify the function.

Example:

ROUND → RO

FIX → FI

ATAN → AT, etc...

- **Priority of operations**

The order of operations is as follows:

1. Functions
2. Operations such as multiplication and division (*, /, AND)
3. Operations such as addition and subtraction (+, -, OR, XOR)

- **Bracket nesting**

Brackets are used to change the order of operations. Brackets can be used to a depth of ten levels including the brackets used to enclose a function.

When a depth of ten levels is exceeded, an error occurs.

Example: #1=SIN[[#2+#3] *#4 +#5] *#6]

1. The content of #3 is added to the content of #2.
2. The result of operation 1 is multiplied by the content of #4.
3. The content of #5 is added to the result of operation 2.
4. The result of operation 3 is multiplied by the content of #6.
5. The result of operation 4 is the value passed to the SIN[] function.