

Manual

5 Axis CNC Interface Breakout Board

Model#-DB25-1R5AM

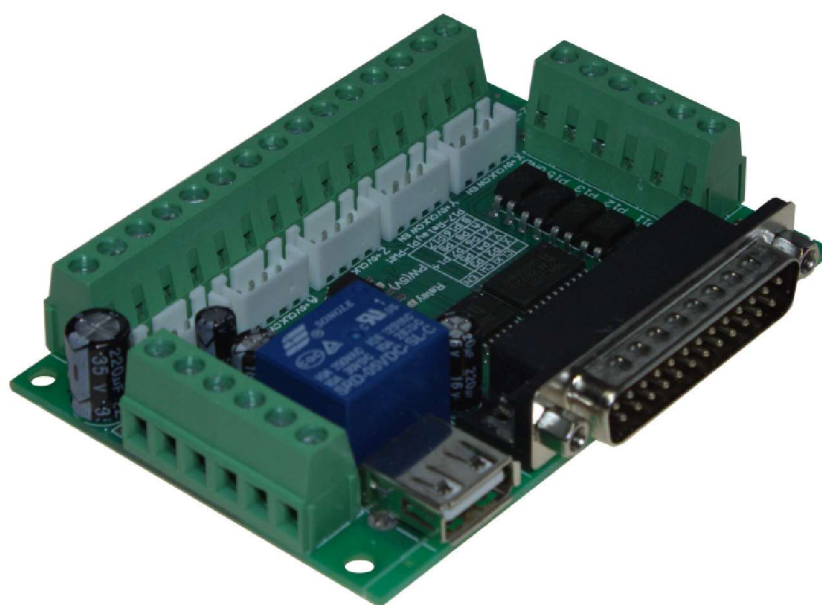

Read this manual carefully before making connections to the board.
Store this manual away for further reference.

Safety Notes:

The electronics of the control board is designed to accept DC power ONLY. Ensure that the positive and negative connections are made correctly before powering on the unit. Incorrect wiring will cause damage to the board.

The control board is an open circuit design. Do not allow conductive objects such as small pieces of wire or stray pieces of metal to touch any of part of the circuit. Mount inside an inclosure using insulated (plastic) stand offs or insulating pads. Do not mount directly to any conductive metal or aluminum plates. Handle with care, do not drop or touch the electronic parts on the board.

Keep the board from damp environment.

Keep the board in adequate ventilation.

Keep the board from mechanical damage.

Note: the DB25-1205M, has a male 25 pin line printer port input to be used with a female parallel printer cable.



It can not be used with serial printer cables, usb to serial printer cord adapters, or any other cable that is not a parallel printer cable .

If your computer does not come with a DB25 parallel printer port, one may be installed.

To avoid frustration be sure you have the right cable.

Model#-DB25-1R5AM

Usage:

The DB25-1R5AM control board is designed for MACH3 CNC software and other CNC programs that utilizes the computers DB25 line printer port. The control board is extensively used in the CNC industry. Such as CNC engraving machines, CNC lathes, CNC plasma cutting machines, CNC laser engraving machines, CNC milling machines, etc.

The use of the DB25-1R5AM is designed to put an isolation buffer between the computers sensitive electronics and the high current and voltages of the control (motor) drivers. The board also aids in making easy connections of the line printer port and to help boost signal strength.

Model#-DB25-1R5AM

Features:

This must be energized to operate the control board.

3. One relay is designed into the board that can be programmed to control external equipment such as a solenoid valve, cooling pump and so on. A secondary power supply (24VDC) is required to energize the relay on the board and for signal inputs. This is used as the analog power supply and is isolated from the d1.

2. Absolute voltage isolation. The CNC control board is powered by the computers USB port and is used as a digital power supply that is designed as common cathode and common anode, which is connected to the motor driver's common port.

Note: digital power supply through the use of an optocoupler.

Note: this power source is not required if the relays are not intended for use.

4. Five signal ports are isolated by optocouplers which can be used for limit switches, position switches, finding origin points, starting and emergency stopping.

5. Ten output ports can control five motors simultaneously (5 Axis control). They can also be programmed to be used as single outputs. Some ports are communally designed for two functions (input or output)

and should be selected as required by the user.

6. Programmed analog voltage from 0 VDC to 10 VDC can be programmed to control the speed of a spindle motor.

7. The CNC control board can control stepper motor drivers with common cathode or common anode connections. It also can control a servo motor with digital signal.

Model#-DB25-1R5AM

Note: The DB25M-3R6A is equipped with a USB port. This port is for supplying power to the board. It is not used for any communication with the computer or with the board. It is strictly used as a power supply input.

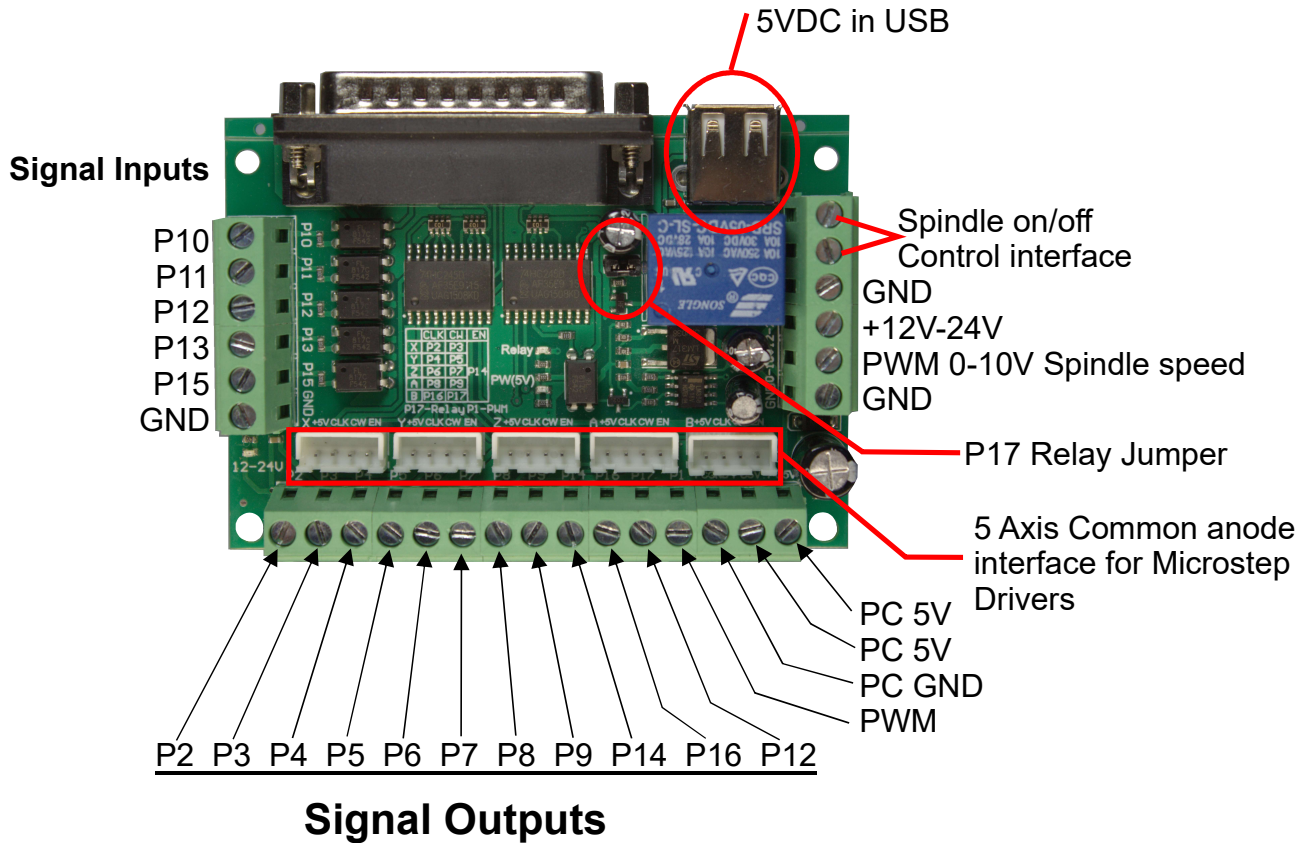

P2 is for X axis pulse, P3 is for X axis direction.
 P4 is for Y axis pulse, P5 is for Y axis direction.
 P6 is for X axis pulse, P7 is for Z axis direction.
 P8 is for A axis pulse, P9 is for A axis direction.

P14 Enable

P16 is for B axis pulse, P17 is for B Axis direction

NOTE:

P17 can be used for controlling the onboard relay.

Removing jumper: P17 as B axis direction.

Connecting jumper: P17 as Relay control.

Model#-DB25-1R5AM

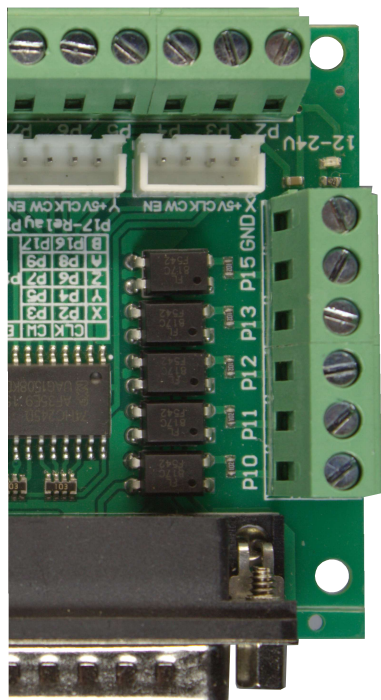

Signal Inputs

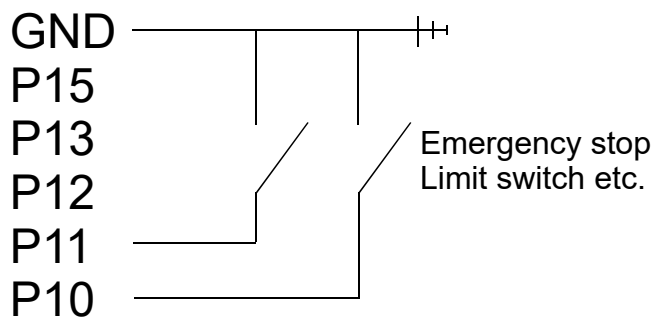

12Vdc power supply required for signal inputs.

Signal inputs P10 - P15 can connect to a sensor or switch.
The inputs then can be recognized by the software.

Example of connection:

- P10 Emergency Stop
- P11 Tool Setting
- P12 X axis limit switch
- P13 Y axis limit switch
- P15 Z axis limit switch

Model#-DB25-1R5AM

www.StepperMotorCanada.ca

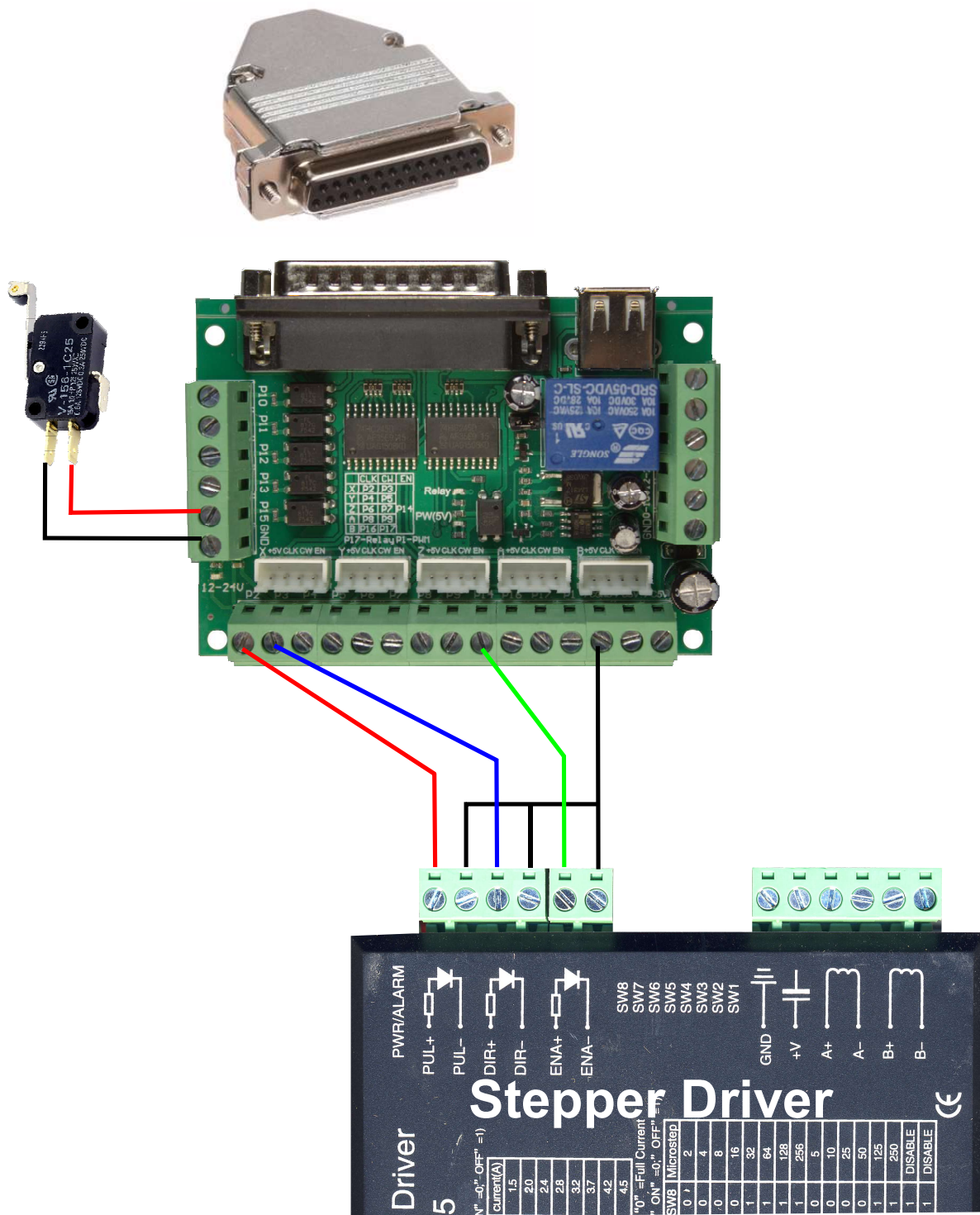

Model#-DB25-1R5AM